

HE-8000

パーツブック
PARTS BOOK

本縫電子ボタン穴かがりミシン
ELECTRONIC LOCKSTITCH BUTTON HOLDER

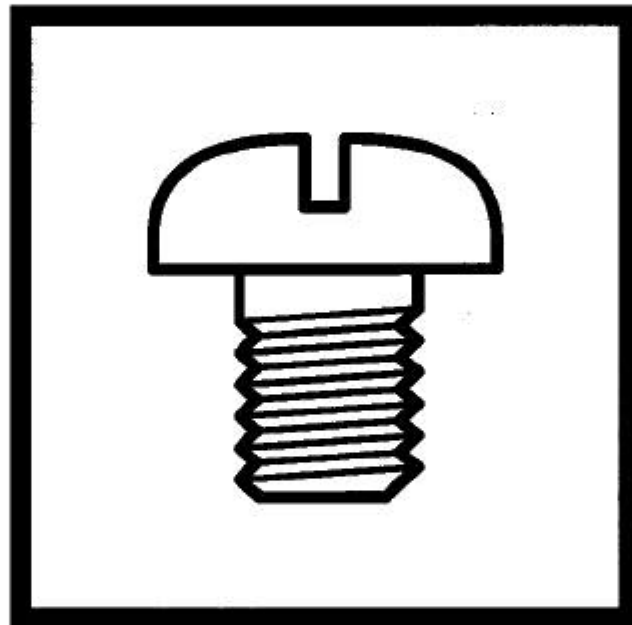

brother®

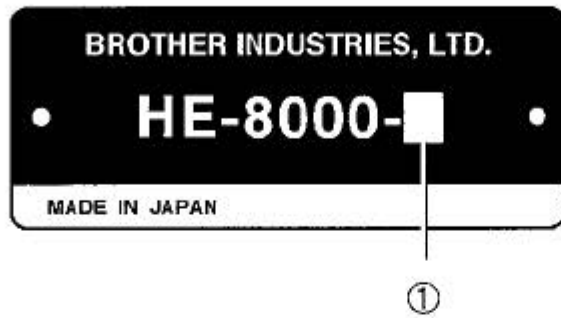

- ① — 2 : 布帛用 / For General materials
- ① — 3 : ニット用 / For Knitted materials
- ① — 5 : 長穴用 (70mm) / For long-hole (70mm)

パーツブックご利用に際して

- 1 この本は、2002年5月のデータに基づいて作成されたものです。
- 2 部品は予告なしに設計変更される場合があります。
- 3 組単位で補給する部品は、[] 破線で示しております。

目 次

A.	主体関係	1	T.	操作パネル関係	43
B.	針棒・天秤関係	3	U1.	コントロールボックス関係	45
C.	上軸関係	5	U2.	コントロールボックス関係	49
D.	針振関係	7	U3.	コントロールボックス関係	53
E.	非常停止関係	7	V.	電装品関係	57
F.	押工関係	9	W.	プリント基板関係	59
G1.	送り関係 (-2,-3)	13	X1.	付属装置関係 (オプション部品)	61
G2.	送り関係 (-5).....	17	X2.	付属装置関係 (オプション部品)	63
H.	カッター関係	19	Y.	モータ関係	65
J.	糸切れ感知関係	21	AA.	カバー関係	67
K.	下軸関係	21	Z1.	付属品関係	67
L.	カム関係	23	Z2.	付属品関係	69
M.	給油潤滑関係	25	Z3.	付属品関係	73
N.	糸通シ関係	29	Ga1.	ゲージ部品一覧表	75
P.	糸巻関係	33	Ga2.	ゲージ部品一覧表	76
Q.	上糸切り関係.....	35	Ga3.	ゲージ部品一覧表	77
R.	下糸切り関係.....	39	Wa.	警告ラベル	78
S.	針位置検出器関係.....	43		索引	79

Notes for using this parts book

- 1 This book was prepared based on information available in May 2002.
- 2 Parts are subject to changes in design without prior notice.
- 3 Parts supplied as complete assemblies are circled by a dotted line [.....].

CONTENTS

A. Machine body.....	1	T. Operation panel mechanism.....	43
B. Needle bar and thread take-up mechanism.....	3	U1. Control box mechanism.....	45
C. Upper shaft mechanism.....	5	U2. Control box mechanism.....	49
D. Zigzag mechanism.....	7	U3. Control box mechanism.....	53
E. Emergency stop mechanism.....	7	V. Power supply equipment mechanism....	57
F. Presser foot mechanism.....	9	W. Printed circuit board mechanism.....	59
G1. Feed mechanism (For "-2&-3").....	13	X1. Attachment set (Option parts).....	61
G2. Feed mechanism (For "-5").....	17	X2. Attachment set (Option parts).....	63
H. Cutter mechanism.....	19	Y. Motor mechanism.....	65
J. Thread breakage detector mechanism.	21	AA. Safety cover.....	67
K. Lower shaft mechanism.....	21	Z1. Accessories.....	67
L. Rotary hook mechanism.....	23	Z2. Accessories.....	69
M. Lubrication.....	25	Z3. Accessories.....	73
N. Threading mechanism.....	29	Ga1. Gauge parts List.....	75
P. Bobbin winder mechanism.....	33	Ga2. Gauge parts List.....	76
Q. Upper thread trimmer mechanism.....	35	Ga3. Gauge parts List.....	77
R. Lower thread trimmer mechanism.....	39	Wa. Warning labels.....	78
S. Synchronizer.....	43	Index	79

A. 主体関係 / Machine body

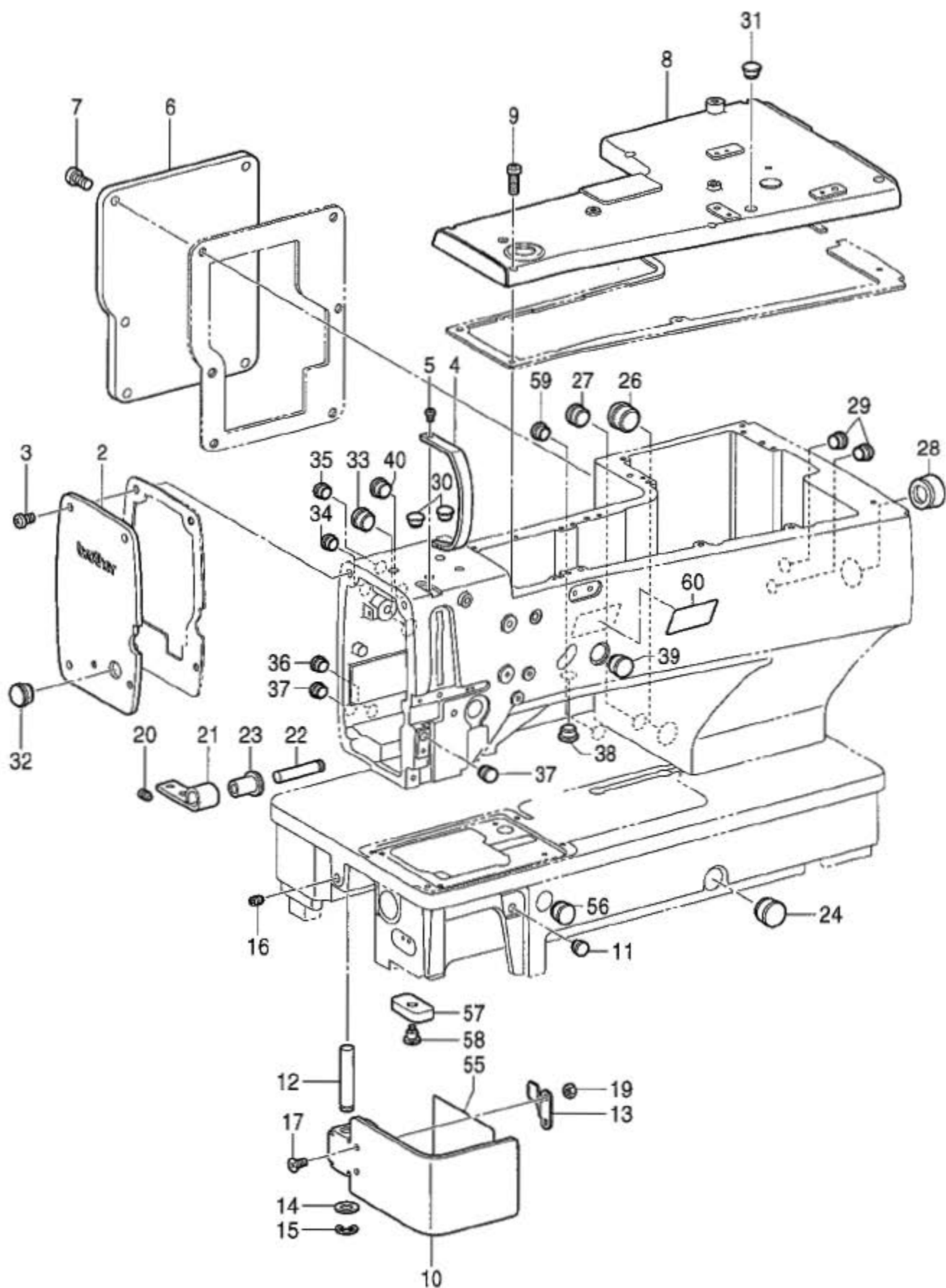

118-H80-050

A.主体関係 / Machine body

REF.NO	CODE	QTY	品名	NAME OF PARTS	RM
2	S50124001	1	メンタ	FACE PLATE	
3	062711012	4	ナハコ476-32X10	SCREW, PAN SM4.76-32X10	
4	S50125001	1	テレソカハ-	COVER, ;T/TAKE-UP LEVER	
5	062680612	1	ナハコ4.37-40X6	SCREW, PAN SM4.37-40X6	
6	S50126001	1	カワタ	REAR COVER	
7	062711012	6	ナハコ476-32X10	SCREW, PAN SM4.76-32X10	
8	S50127001	1	ウワフタ	TOP COVER	
9	062711612	6	ナハコ476-32X16	SCREW, PAN SM4.76-32X16	
10	S50128001	1	カマカハ-	COVER, ;R-HOOK	
11	104450101	1	ゴムセン8	RUBBER CAP, 8	
12	158879001	1	カマカハ-シク	SHAFT, ;R-HOOK COVER	
13	S00306001	1	ヒンジイタハネ	SPRING, PLATE	
14	025080132	1	ヒラサガネシヨウ8	WASHER, PLAIN S 8	
15	048060342	1	トメE6	RETAINING RING, E6	
16	014760622	1	アトメネシ5.95	SET SCREW, SOCKET SM5.95	
17	117143003	2	サラネシ4.37	SCREW, FLAT SM4.37	
19	021680202	2	ナツトシヨウ4.37	NUT, 2 SM4.37	
20	014760622	2	アトメネシ5.95	SET SCREW, SOCKET SM5.95	
21	158830001	2	ヒンジ	BED HINGE	
22	158831001	2	ヒンジピン	PIN	
23	158832000	2	ヒンジピンサエコム	PIN SUPPORT RUBBER	
24	159150000	1	ゴムセン20.5	RUBBER CAP, 20.5	
25	117934001	1	ゴムセン13.5	RUBBER CAP, 13.5	
26	159150000	1	ゴムセン20.5	RUBBER CAP, 20.5	
27	104449001	1	ゴムセン15.5	RUBBER CAP, 15.5	
28	104451101	1	ゴムセン23.9	RUBBER CAP, 23.9	
29	104450101	2	ゴムセン8	RUBBER CAP, 8	
30	104450101	2	ゴムセン8	RUBBER CAP, 8	
31	104450101	1	ゴムセン8	RUBBER CAP, 8	
32	104449001	1	ゴムセン15.5	RUBBER CAP, 15.5	
33	104449001	1	ゴムセン15.5	RUBBER CAP, 15.5	
34	104450101	1	ゴムセン8	RUBBER CAP, 8	
35	104450101	1	ゴムセン8	RUBBER CAP, 8	
36	104450101	1	ゴムセン8	RUBBER CAP, 8	
37	104450101	2	ゴムセン8	RUBBER CAP, 8	
38	104450101	1	ゴムセン8	RUBBER CAP, 8	
39	104449001	2	ゴムセン15.5	RUBBER CAP, 15.5	
40	S32263001	3	ゴムセン8.5	RUBBER CAP, 8.5	
55	S50131001	1	イトオシツメイタ	THREADING DIAGRAM	
56	104449001	1	ゴムセン15.5	RUBBER CAP, 15.5	
57	S50340000	2	ベツタイクダシヨウ	BED BASE CUSHION	
58	120263001	2	ダンネシ4.37	SCREW	
59	117936001	1	ゴムセン9.4	RUBBER CAP, 9.4	
60	S44629002	1	E7-ク	LABEL, E	

B. 針棒・天秤関係 / Needle bar and thread take-up mechanism

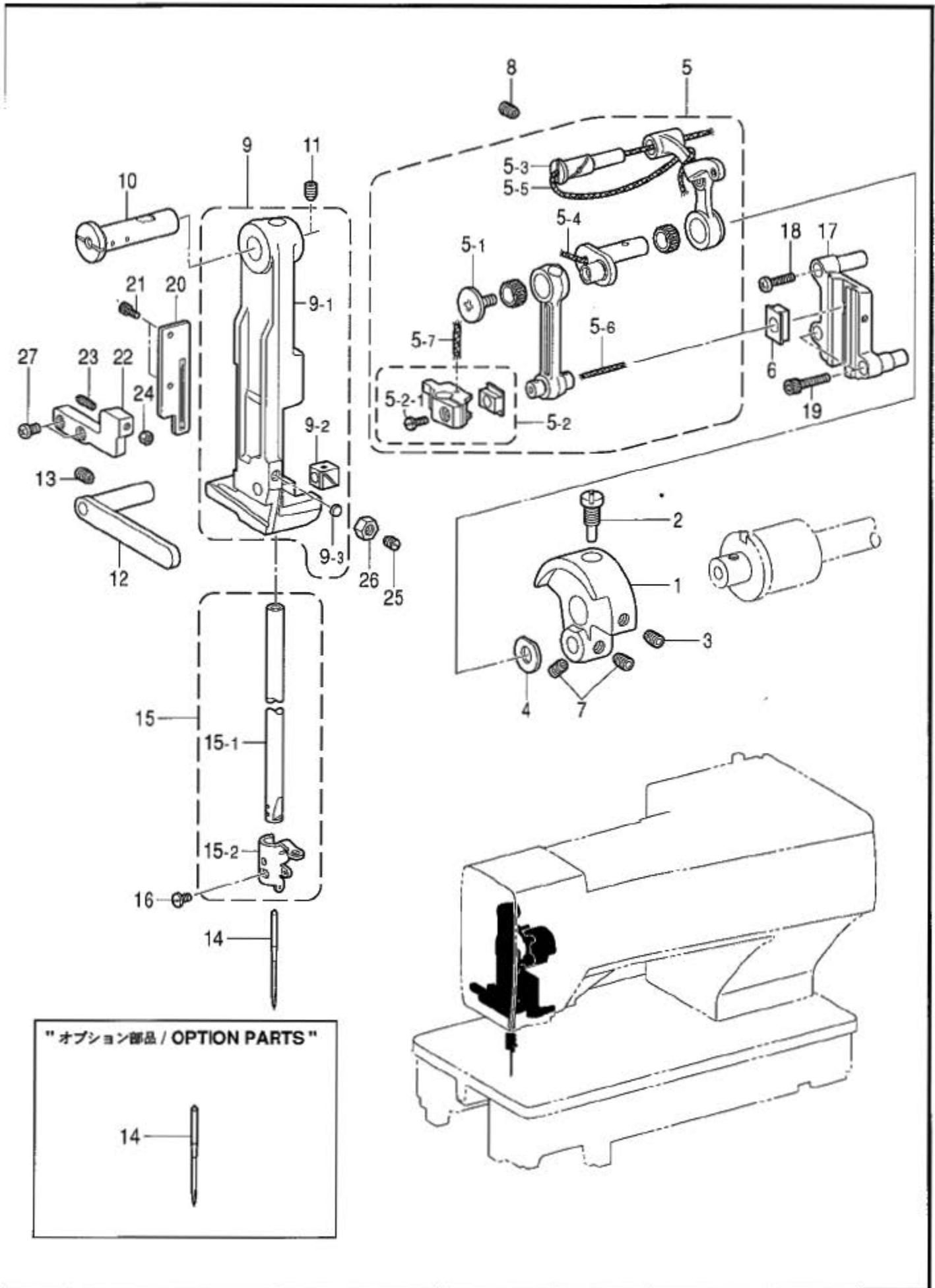

118-H80-101

B.針棒・天秤関係 / Needle bar and thread take-up mechanism

REF.NO	CODE	QTY	ヒンメイ	NAME OF PARTS	RM
1	S50132000	1	テビ`ンクラク	THREAD TAKE-UP CRANK	
2	100250001	1	シメネシ`7.14	SCREW, SM7.14	
3	014770622	1	アトメネシ`6.35クホ`ミ	SET SCREW, SOCKET (CP) SM6.35	
4	110367001	1	サ`カ`ネ	WASHER, PLAIN SPECIAL 8	
5	S50133001	1	ハリホ`ウレンカクミ	THREAD TAKE-UP LEVER SET	
5-1	145465001	1	シメネシ`3.57L	SCREW, SM3.57-40X6 L	
5-2	S50136001	1	ハリホ`ウタ`キノウクミ	NEEDLE BAR CLAMP SET	
5-2-1	140004001	1	シメネシ`3.57	SCREW, SM3.57-40X7	
5-3	S52943001	1	テビ`ンササエシ`ク	SUPPORT SHAFT	
5-4	140430001	1	クミ`モ	WICK, L=40	
5-5	S50142000	1	クミ`モ3X290	WICK, 3X30	
5-6	S50271000	1	クミ`モ2X35	WICK, 2X35	
5-7	S50272000	1	クミ`モ3X15	WICK, 3X15	
6	S52248001	1	ハリホ`ウアンナイカクマ	SLIDE BLOCK, ;N-BAR BRACKET	
7	014770622	2	アトメネシ`6.35クホ`ミ	SET SCREW, SOCKET (CP) SM6.35	
8	014760622	1	アトメネシ`5.95	SET SCREW, SOCKET SM5.95	
9	S50143001	1	ハリホ`ウタ`イノウクミ	NEEDLE BAR BRACKET SET	
9-1	S50144001	1	ハリホ`ウタ`イ`クミ	NEEDLE BAR BRACKET ASSY	
9-2	159624001	1	ハリホ`ウタ`イカクマ	SLIDE BLOCK, ;N-BAR BRACKET	
9-3	S50146001	1	ストップ`ハ`イ`タ	STOPPER PLATE	
10	158888001	1	ハリホ`ウタ`イササエシ`ク	SUPPORT SHAFT, ;N-BAR BRACKET	
11	014760622	1	アトメネシ`5.95	SET SCREW, SOCKET SM5.95	
12	S50147001	1	ハリホ`ウタ`イアンナイ	GUIDE, ;N-BAR BRACKET	
13	014760622	1	アトメネシ`5.95	SET SCREW, SOCKET SM5.95	
14	S50180075	1	<国内-2用、-3用> ミシンハリ134 <#11 NM75>	NEEDLE, NM75	
14	S50180090	1	<輸出-2用、-5用> ミシンハリ134 <#14 NM90> "オプション部品"	NEEDLE, NM90 "OPTION PARTS"	
14	S50180065	1	ミシンハリ134 <#9 NM65>	NEEDLE, NM65	
14	S50180070	1	ミシンハリ134 <#10 NM70>	NEEDLE, NM70	
14	S50180080	1	ミシンハリ134 <#12 NM80>	NEEDLE, NM80	
14	S50180085	1	ミシンハリ134 <#13 NM85>	NEEDLE, NM85	
14	S48371060	1	ミシンハリ134SUK <#14 NM90>	NEEDLE, NM60	
14	S48371065	1	ミシンハリ134SUK <#9 NM65>	NEEDLE, NM65	
14	S48371070	1	ミシンハリ134SUK <#10 NM70>	NEEDLE, NM70	
14	S48371075	1	ミシンハリ134SUK <#11 NM75>	NEEDLE, NM75	
14	S48371080	1	ミシンハリ134SUK <#12 NM80>	NEEDLE, NM80	
14	S48371090	1	ミシンハリ134SUK <#14 NM90>	NEEDLE, NM90	
15	S50148001	1	ハリホ`ウクミ	NEEDLE BAR ASSY	
15-1	158885201	1	ハリホ`ウ	NEEDLE BAR	
15-2	S50149101	1	ハリホ`ウイトアンナイ	THREAD GUIDE, ;N-BAR	
16	140553102	1	アタマツキトメネシ`3.18	SET SCREW, SM3.18	
17	S50150001	1	クラク`ロフト`アンナイ	CRANK ROD GUIDE	
18	S31808001	1	ハ`コ`437-40X25	SCREW, PAN SM4.37-40X25	
19	150382001	2	アナホ`ルト4.37X18	BOLT, SOCKET SM4.37X18	
20	S50152001	1	ハリホ`ウアンナイ	GUIDE, ;N-BAR	
21	154965001	2	アナホ`ルト3.57X8	BOLT, SOCKET SM3.57X8	
22	S50153001	1	ハリホ`ウタ`イストップ`ハ`	STOPPER	
23	153483001	1	トメネシ`4.76	SET SCREW, SM4.76	
24	021710202	1	ナツト2シ`4.76	NUT, 2 SM4.76	
25	013761410	1	トメネシ`5.95クホ`ミ	SET SCREW, (CP) SM5.95X14	
26	100022005	1	ナツト5.95	NUT, SM5.95	
27	062681012	2	ハ`コ`437-40X10	SCREW, PAN SM4.37-40X10	

C . 上軸關係 / Upper shaft mechanism

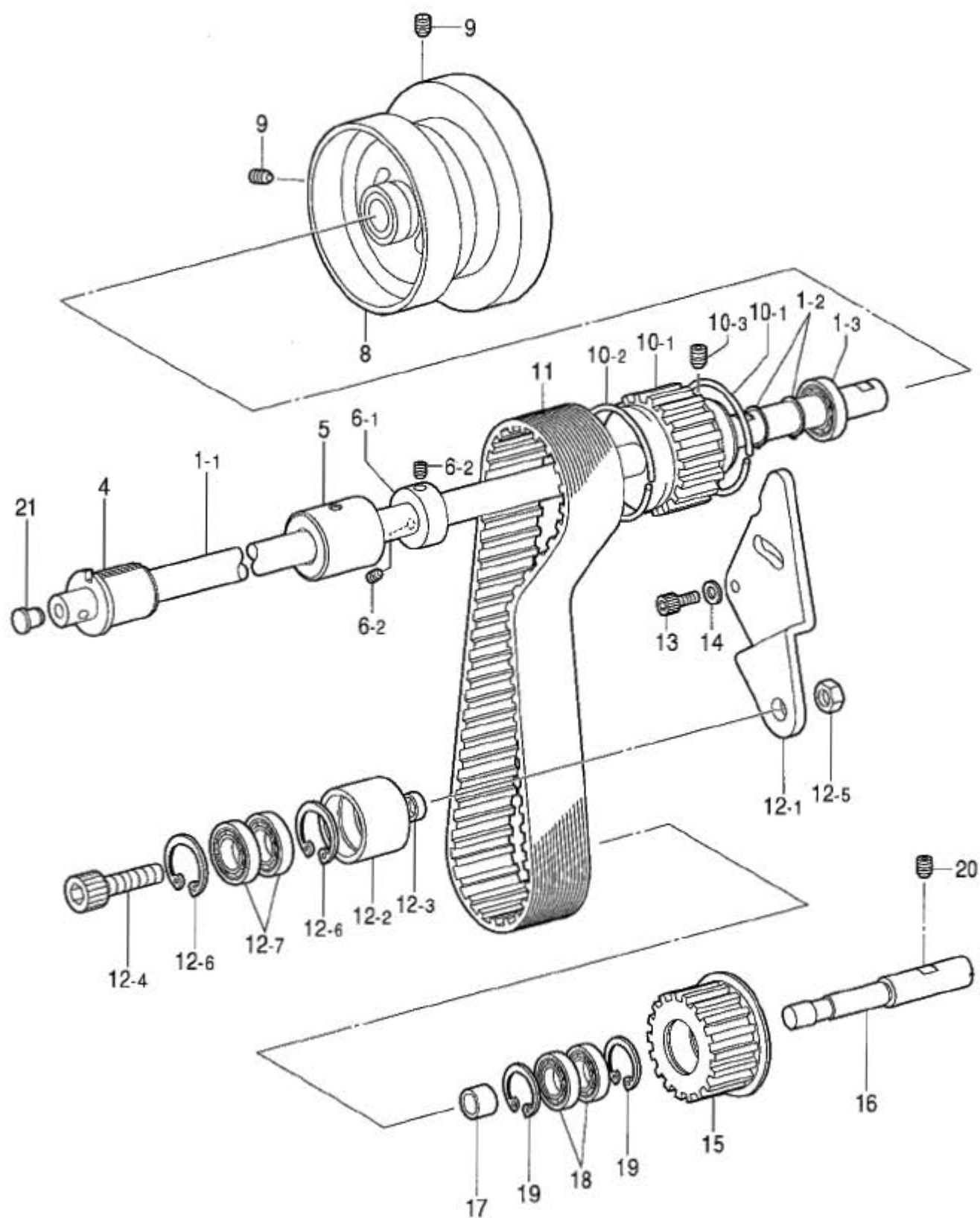

C.上軸関係 / Upper shaft mechanism

REF.NO	CODE	QTY	ヒンメイ	NAME OF PARTS	RM
1	S51176001	1	ウツシククミ	UPPER SHAFT ASSY	
1-1	S50154001	1	ウツシク	UPPER SHAFT	
1-2	048150142	2	トメワシクヨウC15	RETAINING RING, EXTERNAL C15	
1-3	072630260	1	ハアリク 6302VV	BALL BEARING, 6302VV	
4	S50155001	1	ウツシクメタAF	BUSH, F	
5	158893000	1	ウツシクメタAM	BUSH, M	
6	S51223001	1	セツカークミ	SET SCREW COLLAR ASSY	
6-1	S50156001	1	セツカーク	SET SCREW COLLAR	
6-2	014780622	2	アトメネシ 6.35クホミ	SET SCREW, SOCKET (CP) SM6.35	
8	S50157001	1	プーリクミ	PULLEY ASSY	
9	014760622	2	アトメネシ 5.95	SET SCREW, SOCKET SM5.95	
10	S50159001	1	タイミンクフーリウクミ	T-PULLEY ASSY, U	
10-1	S50160001	1	タイミンクフーリウ	T-PULLEY, U	
10-2	S48034001	2	タイミンクフーリウク	RING	
10-3	014780622	2	アトメネシ 6.35クホミ	SET SCREW, SOCKET (CP) SM6.35	
11	S50161000	1	タイミンクハト	TIMMING BELT	
12	S50162001	1	テンションフーリクミ	TENSION PULLEY ASSY	
12-1	S50163001	1	テンションフーリウ	PLATE, T-PULLEY	
12-2	S50164001	1	テンションフーリ	TENSION PULLEY	
12-3	S50165001	1	テンションフーリカーク	COLLAR	
12-4	018102536	1	アホト 10X25	BOLT, SOCKET M10X25	
12-5	021100302	1	ナツト 3 M10	NUT, 3 M10	
12-6	048300242	2	トメワシクヨウC30	RETAINING RING, INTERNAL C30	
12-7	076200800	1	タマシクウケ6200ZZ	BALL BEARING, 6200ZZ	
13	018061022	2	アホト 6X10	BOLT, SOCKET M6X10	
14	025060232	2	ヒラサガネチウ6	WASHER, PLAIN M 6	
15	S50166001	1	アイトラフーリ	IDLER PULLEY	
16	S50167001	1	アイトラフーリシク	SHAFT	
17	S50168001	1	アイトラフーリカーク	COLLAR	
18	070608800	2	タマシクウケ608ZZ	BALL BEARING 0608ZZ	
19	048220242	2	トメワシクヨウC22	RETAINING RING, INTERNAL C22	
20	014780622	2	アトメネシ 5.95	SET SCREW, SOCKET SM5.95	
21	111865001	1	セン6	CAP, 6	

D. 針振關係 / Zigzag mechanism

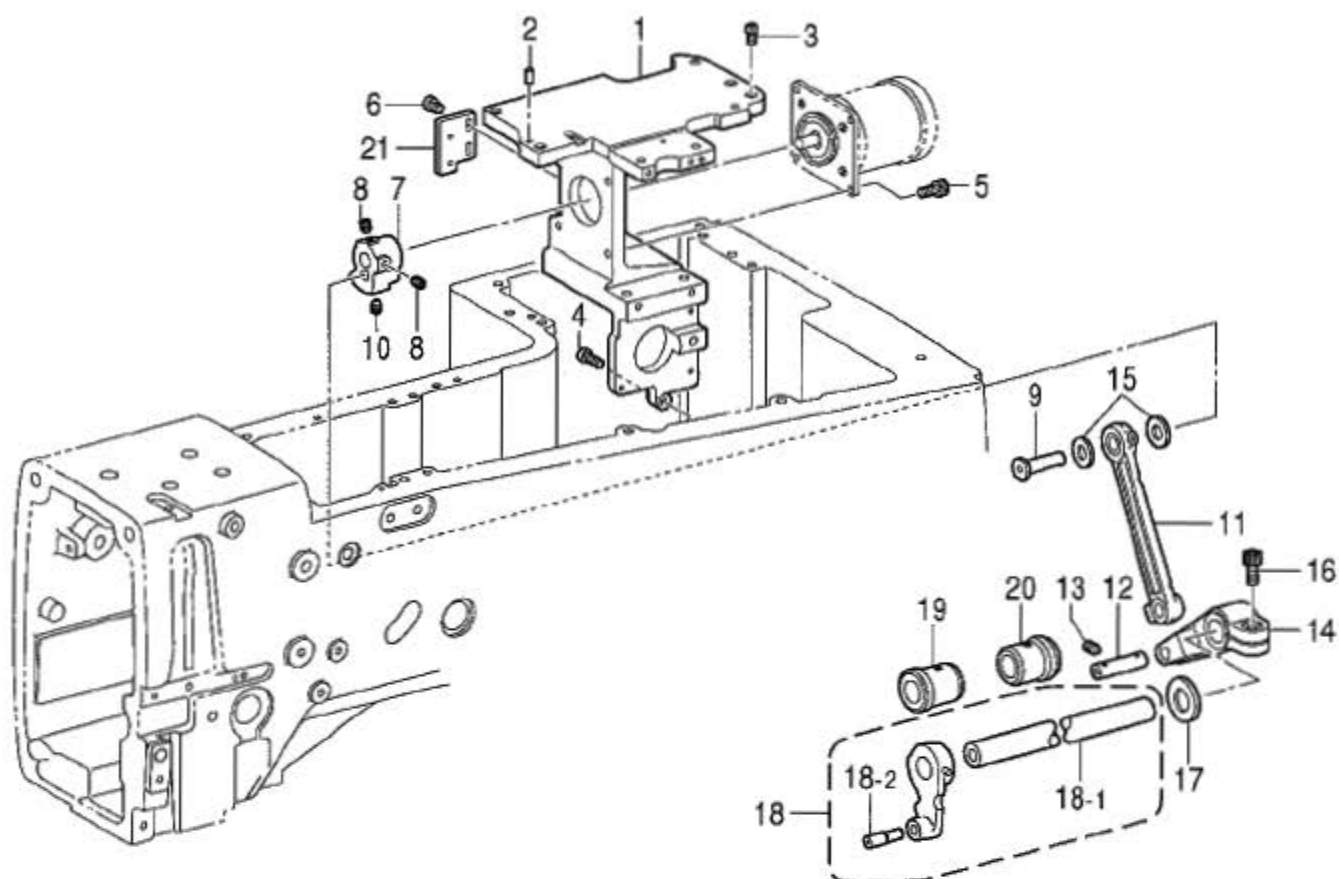

118-H80-110

E. 非常停止關係 / Emergency stop mechanism

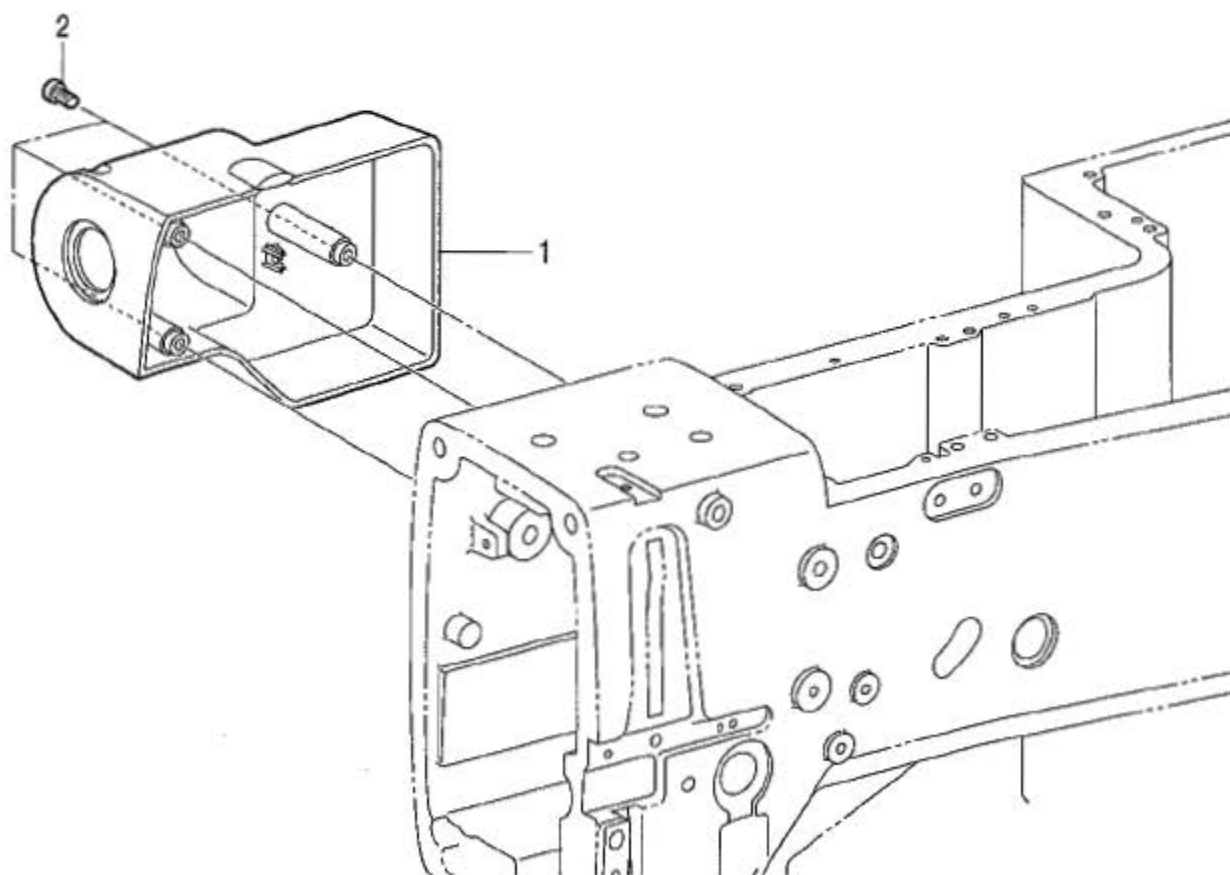

118-H80-114

D.針振関係 / Zigzag mechanism

REF.NO	CODE	QTY	ヒンメイ	NAME OF PARTS	RM
1	S50169001	1	モータブラケット	MOTOR BRACKET	
2	S37940001	2	イキピン	POSITIONING PIN	
3	062711212	4	ナット476-32X12	SCREW, PAN SM4.76-32X12	
4	062711612	1	ナット476-32X16	SCREW, PAN SM4.76-32X16	
5	018401222	4	ソケットボルト4X12	BOLT, SOCKET M4X12	
6	060300612	2	バインド M3X6	SCREW, BIND M3X6	
7	S50170001	1	モーターレバー	MOTOR LEVER	
8	014760622	2	アトメネジ 5.95	SET SCREW, SOCKET SM5.95	
9	S50171001	1	モーターレバーシャフト	LEVER SHAFT, ;MOTOR	
10	014760622	1	アトメネジ 5.95	SET SCREW, SOCKET SM5.95	
11	S50172001	1	ハリフリンカン	ZIGZAG CONNECTING ROD	
12	S51190001	1	ハリフリンカンシャフト	SHAFT, ;Z-CONNECTING ROD	
13	014760622	1	アトメネジ 5.95	SET SCREW, SOCKET SM5.95	
14	S50174001	1	ハリフリンレバー	LEVER, ;ZIGZAG	
15	118735001	2	ワッシャー	WASHER, PLAIN 6	
16	018061622	1	ソケットボルト6X16	BOLT, SOCKET M6X16	
17	S32521001	1	スラストワッシャー	WASHER, THRUST	
18	S50176001	1	ハリフリンレバーFクミ	ZIGZAG LEVER ASSY, F	
18-1	S50178001	1	ハリフリンレバーシャフト	SHAFT, ;Z-LEVER	
18-2	159625001	1	レバーFカクゴマシク	STUD	
19	158945001	1	ハリフリンクメタルF	BUSH, F ;Z-LEVER	
20	158946001	1	ハリフリンクメタルR	BUSH, R ;Z-LEVER	
21	S50179001	1	ハリフリンセンサ	PLATE, ;Z-SENSOR	

118-H80-110

E.非常停止関係 / Emergency stop mechanism

REF.NO	CODE	QTY	ヒンメイ	NAME OF PARTS	RM
1	S50182000	1	ヒジヨウテイシカカバー	COVER, ;EM	
2	062400806	3	ナット4X8	SCREW, PAN M4X8	

118-H80-114

F. 押工關係 / Presser foot mechanism

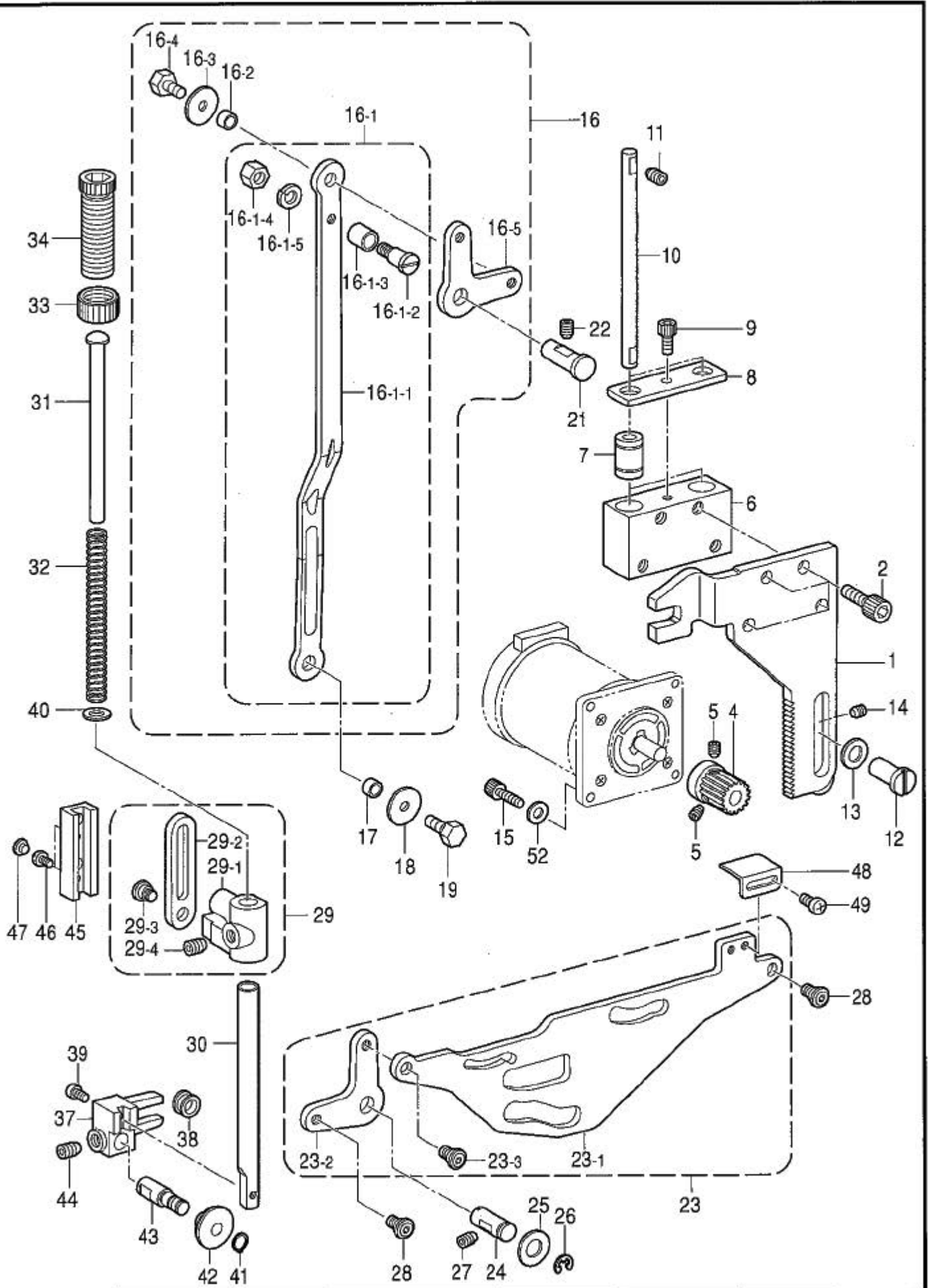

F.押工関係 / Presser foot mechanism

REF.NO	CODE	QTY	ヒンメイ	NAME OF PARTS	RM
1	S50183001	1	オシエトウウチ	DRIVING ARM, ;PRESSER	
2	018061022	4	アホソ 母6X10	BOLT, SOCKET M6X10	
4	S43717201	1	外ウキヤ15.75	GEAR, 15.75	
5	014770622	2	アトメネジ 6.35ホミ	SET SCREW, SOCKET (CP) SM6.35	
6	S50184001	1	オシエトウアンナイ	GUIDE BRACKET	
7	S42116000	2	リニアボールベアリング	LINEAR BALL BEARING	
8	S50185001	1	ベアリングホルダ	HOLDER, ;BEARING	
9	018400822	1	アホソ 母4X8	BOLT, SOCKET M4X8	
10	S50186001	2	アンナイシャフト	GUIDE SHAFT	
11	014760622	4	アトメネジ 5.95	SET SCREW, SOCKET SM5.95	
12	S50187001	1	外ウチオシエ	PRESSER, ;DR-ARM	
13	110367001	1	ワシヤ	WASHER, PLAIN SPECIAL 8	
14	014760622	1	アトメネジ 5.95	SET SCREW, SOCKET SM5.95	
15	018401222	3	アホソ 母4X12	BOLT, SOCKET M4X12	
16	S51174001	1	オシエアケレンコノウミ	CONNECTING ROD SET, ;P-LIFTER	
16-1	S50188001	1	オシエアケレンコノウミ	CONNECTING ROD ASSY, ;P-LIFTER	
16-1-1	S50189001	1	オシエアケレンコ	CONNECTING ROD, ;P-LIFTER	
16-1-2	S50190001	1	オシエレンカンダンネジ	SHOULDER SCREW	
16-1-3	S50191001	1	レンカン	ROLLER	
16-1-4	110161004	1	ナツ4.76	NUT, SM4.76	
16-1-5	028050242	1	ワシヤ カネ 2-5	WASHER, SPRING 2-5	
16-2	S50192001	1	オシエアケカン	SPACER	
16-3	S00902001	1	ワシヤ ウレバワシヤ	WASHER, PLAIN L 4.6 (D)	
16-4	117363001	1	ボルト 4.76	BOLT, SM4.76	
16-5	S38761001	1	ヒサアケレバ	LIFTER LEVER, ;KNEE	
17	S50192001	1	オシエアケカン	SPACER	
18	S00902001	1	ワシヤ ウレバワシヤ	WASHER, PLAIN L 4.6 (D)	
19	117363001	1	ボルト 4.76	BOLT, SM4.76	
21	S50193001	1	オシエアケレバシク	LIFTER SHAFT, A	
22	014760622	1	アトメネジ 5.95	SET SCREW, SOCKET SM5.95	
23	S50194001	1	オシエアケレバ	LIFTER LEVER ASSY, ;P-BAR	
23-1	S50195001	1	ウイトキリク	DRIVING LINK, ;U/TR	
23-2	S38761001	1	ヒサアケレバ	LIFTER LEVER, ;KNEE	
23-3	145478101	1	ダンネジ 4.76	SHOULDER SCREW, SOCKET SM4.76	
24	S50196001	1	オシエアケレバシク	LIFTER SHAFT	
25	025080132	1	ヒラサガネシヨウ	WASHER, PLAIN S 8	
26	048060342	1	トメワ	RETAINING RING, E6	
27	014760622	1	アトメネジ 5.95	SET SCREW, SOCKET SM5.95	
28	145478101	2	ダンネジ 4.76	SHOULDER SCREW, SOCKET SM4.76	
29	S50197001	1	オシエホウダキ	GUIDE BRACKET ASSY, ;P-BAR	
29-1	S50198001	1	オシエホウダキ	GUIDE BRACKET, ;P-BAR	
29-2	S50199001	1	オシエアケリンク	LIFTER LINK, ;P-BAR	
29-3	145478101	1	ダンネジ 4.76	SHOULDER SCREW, SOCKET SM4.76	
29-4	014760622	1	アトメネジ 5.95	SET SCREW, SOCKET SM5.95	
30	111466101	1	オシエホウ	PRESSER BAR	
31	141208001	1	オシエバネアンナイ	SPRING GUIDE	
32	S50200001	1	オシエバネ	SPRING, COMPRESSION	
33	S31013001	1	チヨウセツネジツマミナツ	ADJUSTING NUT, PRESSER	
34	S31012001	1	オシエチヨウセツネジ	ADJUSTING SCREW, PRESSER	
35	140407001	1	ワシヤ	WASHER	
36	145472001	1	オシエホウメタル	BUSH, P-BAR	
37	S50201001	1	オシエロラタイ	ROLLER BRACKET, ;P-BAR	
38	S50202001	1	ハサミササエシク	ROLLER	
39	062671212	1	ナベコ 357-40X12	SCREW, PAN SM3.57-40X12	
40	025060132	1	ヒラサガネシヨウ	WASHER, PLAIN S 6	
41	048060142	1	トメワシク	RETAINING RING, C6	
42	S50203001	1	オシエ	ROLLER	
43	S50204001	1	オシエシク	ROLLER SHAFT	
44	014760622	1	アトメネジ 5.95	SET SCREW, SOCKET SM5.95	
45	S37927000	1	ハリホウアンナイ	GUIDE, ;N-BAR	
46	100242003	2	シメネジ 3.57	SCREW, SM3.57-40X5	

F . 押工關係 / Presser foot mechanism

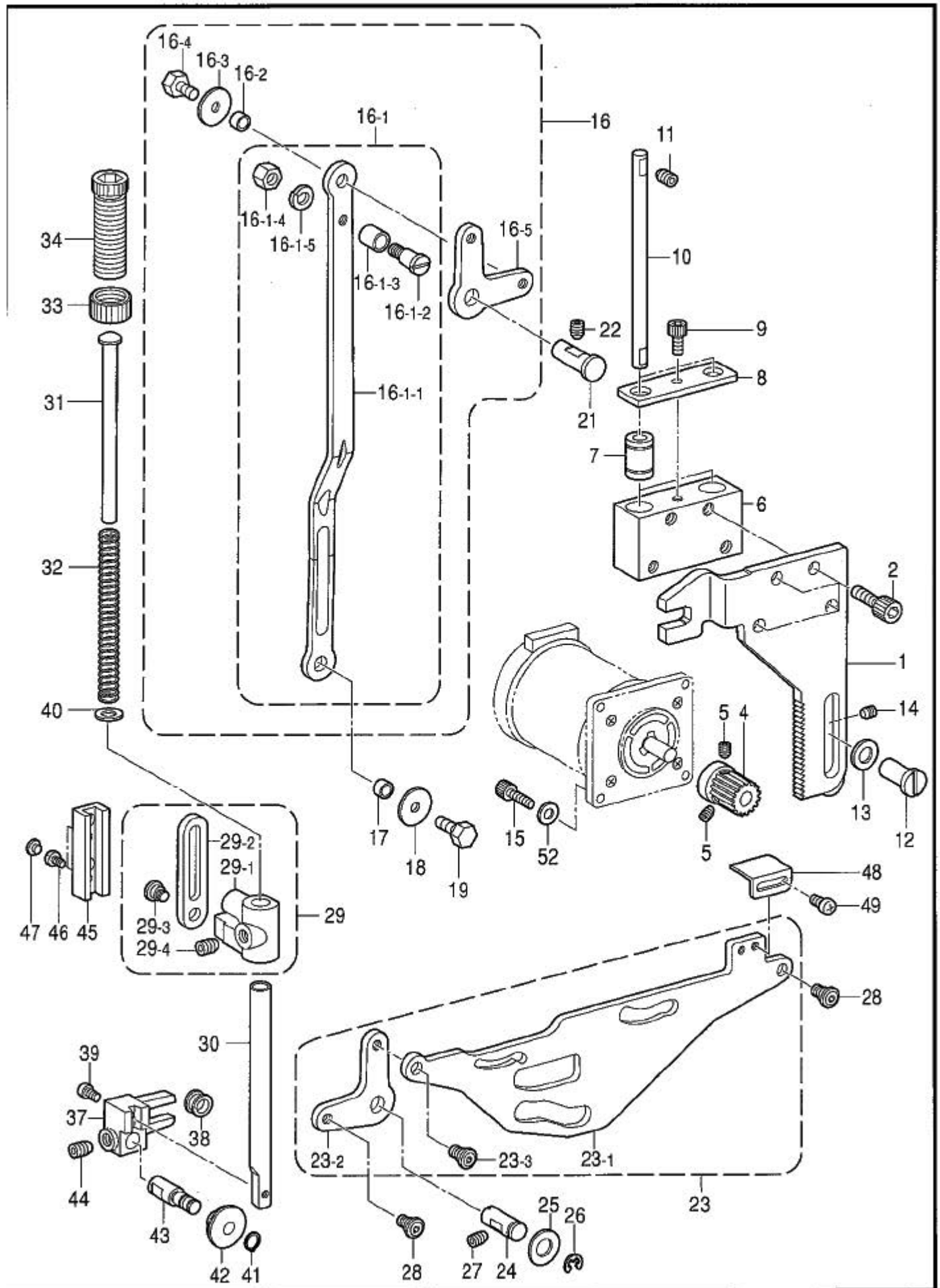

118-H80-201

F.押工関係 / Presser foot mechanism

REF.NO	CODE	QTY	ヒンメイ	NAME OF PARTS	RM
47	155578000	2	ゴム垫7.2	RUBBER CAP, 7.2	
48	S50205001	1	オキセンサトク	DOG, ;CLAMP SENSOR	
49	060670512	2	ハイント 357-40X5	SCREW, BIND SM3.57-40X5	
50	S50206001	1	オキセンサ板	PLATE, ;CLAMP SENSOR	
51	102538002	1	サネシ 3.57	SCREW, FLAT SM3.57	
52	025040232	3	ヒラサ カネチユ4	WASHER, PLAIN M 4	

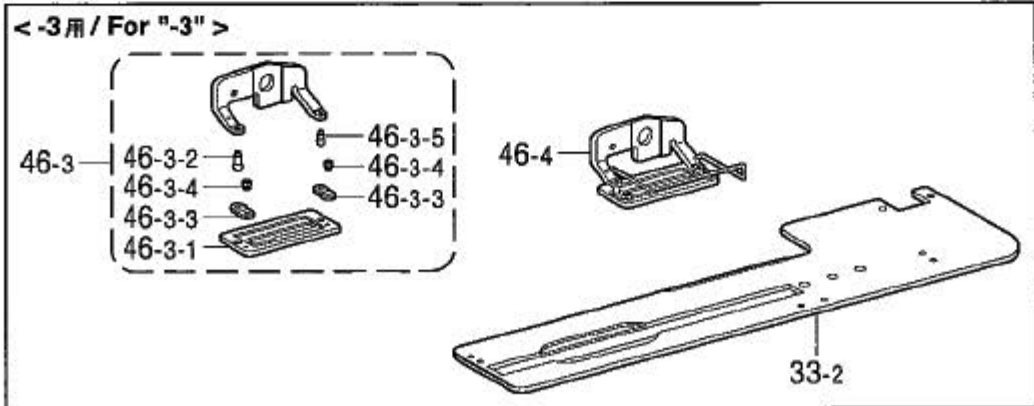
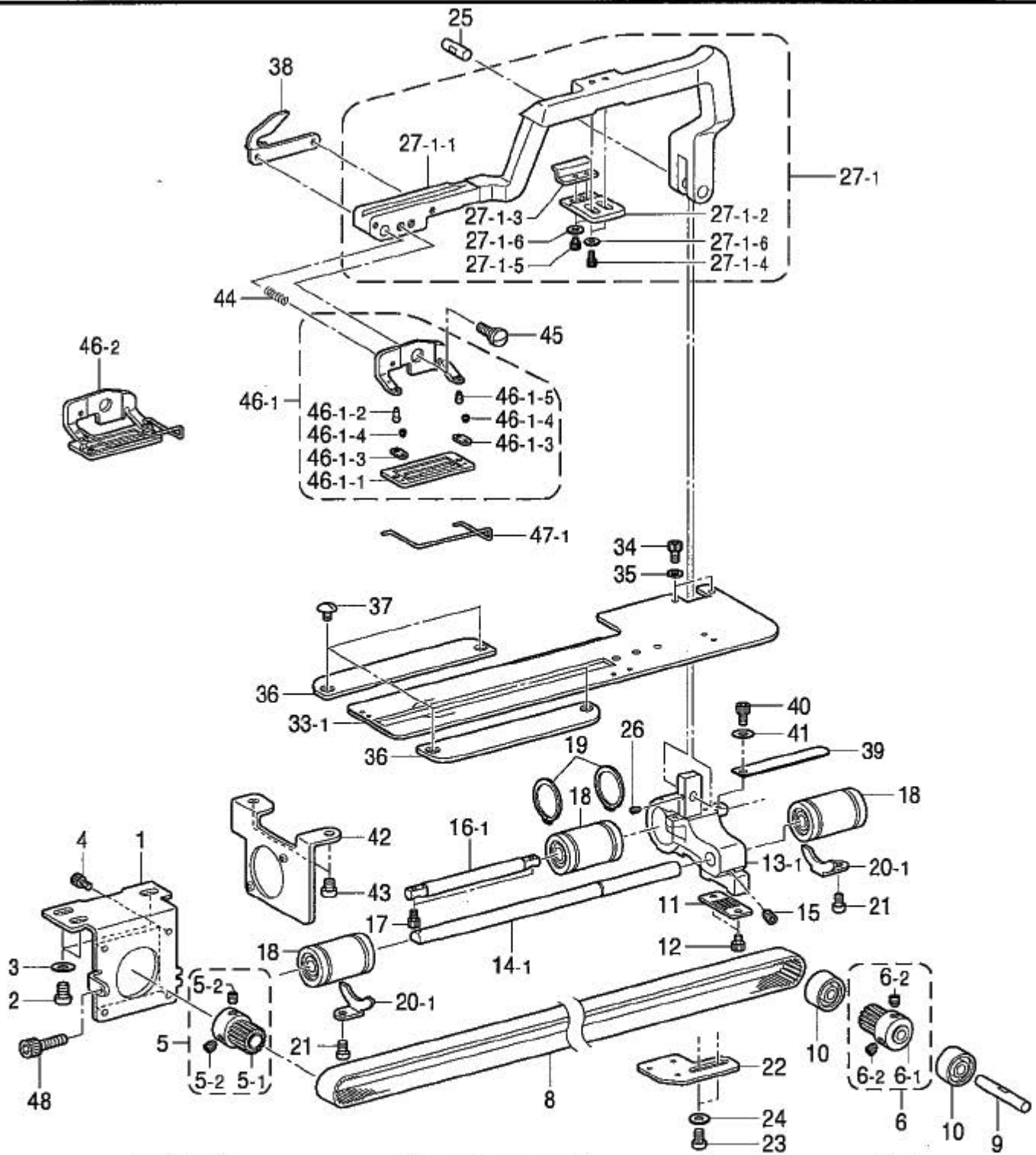

G1.送り関係 (-2,-3)/ Feed mechanism(For "-2 & -3")

REF.NO	CODE	QTY	ヒンメイ	NAME OF PARTS	RM
1	S50207001	1	モータサシイタ	MOUNTING BRACKET, ;MOTOR	
2	062761012	3	ナハコ595-28X10	SCREW, PAN SM5.95-28X10	
3	025060232	3	ヒラサカネシユウ6	WASHER, PLAIN M 6	
4	018401022	4	アナホルト4X10	BOLT, SOCKET M4X10	
5	S51418001	1	オクリウトウフーリアクミ	PULLEY ASSY, A	
5-1	S50208001	1	オクリウトウフーリア	PULLEY, A	
5-2	014060632	2	アナホルトミ6X6	SET SCREW, SOCKET (CP) M6X6	
6	S51225001	1	オクリウトウフーリBクミ	PULLEY ASSY, B	
6-1	S50110001	1	オクリウトウフーリB	PULLEY, B	
6-2	014060632	2	アナホルトミ6X6	SET SCREW, SOCKET (CP) M6X6	
8	S50209000	1	オクリタイミンクハルト	TIMING BELT	
9	S50210001	1	オクリフーリサシイタ	SUPPORT SHAFT	
10	070688850	2	タマシクウケ688ZZNR	BALL BEARING, 688ZZNR	
11	S50211001	1	オクリハルトホダ	BELT HOLDER	
12	018680822	2	アナホルト4.37X8	BOLT, SOCKET SM4.37X8	
13-1	S50212001	1	オクリウテサシイタ	FEED ARM SUPPORT	
14-1	S50213001	1	オクリアンナシク	FEED GUIDE SHAFT, B	
15	014760622	1	アナホルト5.95	SET SCREW, SOCKET SM5.95	
16-1	S50214001	1	オクリアンナシク	SHAFT, A ;F-GUIDE	
17	018681232	2	アナホルト437-40X12	BOLT, SOCKET SM4.37-40X12	
18	S12004000	3	リニアブッシュ	LINEAR BUSH	
19	S02460001	2	トメワシクウケC19	RETAINING RING, EXTERNAL C19	
20-1	S35184001	2	タマシクウケメイト	STOPPER, BALL BEARING	
21	060660416	2	ハイント318-40X4	SCREW, BIND SM3.18-40X4	
22	S50215101	1	オクリセンササシイタ	SUPPORT PLATE, FEED SENSOR	
23	062680812	2	ナハコ437-40X8	SCREW, PAN SM4.37-40X8	
24	025680132	2	ヒラサカネシユウ4.37	WASHER, PLAIN S 4.37	
25	S50216001	1	オクリウテサシイタ	SUPPORT SHAFT, ;F-ARM	
26	012500536	1	アナホルト5X5	SET SCREW, SOCKET (FT) M5X5	
27-1	S51178101	1	オクリウテクミ	FEED ARM ASSY	
27-1-1	S50217001	1	オクリウテ	FEED ARM	
27-1-2	S50218001	1	ニカシカムサシイタ	SUPPORT PLATE	
27-1-3	S50219101	1	ウイトキリニカシカム	CAM	
27-1-4	018681022	2	アナホルト4.37X10	BOLT, SOCKET SM4.37X10	
27-1-5	018680522	2	アナホルト4.37X5	BOLT, SOCKET SM4.37X5	
27-1-6	110735002	4	サカネ	WASHER	
			<-2用>	<For "-2">	
33-1	S50220001	1	ナカサオクリイタ-2	LENGTH FEED PLATE, -2	
			<-3用>	<For "-3">	
33-2	S50225001	1	ナカサオクリイタ-3	LENGTH FEED PLATE, -3	
34	018681022	2	アナホルト4.37X10	BOLT, SOCKET SM4.37X10	
35	028680242	2	ハネサカネ2-4.37	WASHER, SPRING 2-4.37	
36	S50221001	2	オクリオサシイタ	FEED PRESSER PLATE	
37	105130001	4	シメネシ3.57	SCREW, SM3.57	
38	S50222001	1	オクリウテサシイ	FEED ARM SUPPORT	
39	S50223100	1	オクリカハ	COVER	
40	018680822	1	アナホルト4.37X8	BOLT, SOCKET SM4.37X8	
41	025680132	1	ヒラサカネシユウ4.37	WASHER, PLAIN S 4.37	
42	S50224001	1	オクリモータカハ	COVER, ;F-MOTOR	
43	062680612	2	ナハコ4.37-40X6	SCREW, PAN SM4.37-40X6	
44	159078001	1	スノツカミサシイハネ	SPRING	
45	S50562001	1	タンネシ6.35	SHOULDER SCREW, SM6.35	
			<-2用>	<For "-2">	
46-1	159765202	1	スノツカミ25RSクミ	WORK CLAMP ASSY, 25RS	
46-1-1	159762002	1	スノツカミ25RS	WORK CLAMP, 25RS	
46-1-2	159926001	1	スノツカミサシイピン L	PIN, L	
46-1-3	107401001	2	スノツカミサシイイタハネ	SPRING, PLATE	

31 . 送り関係 (-2, -3) / Feed mechanism (For "-2 & -3")

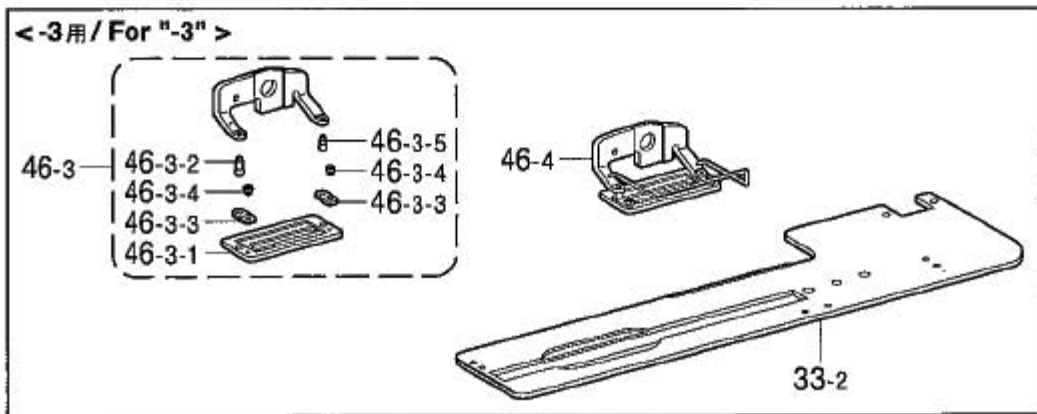
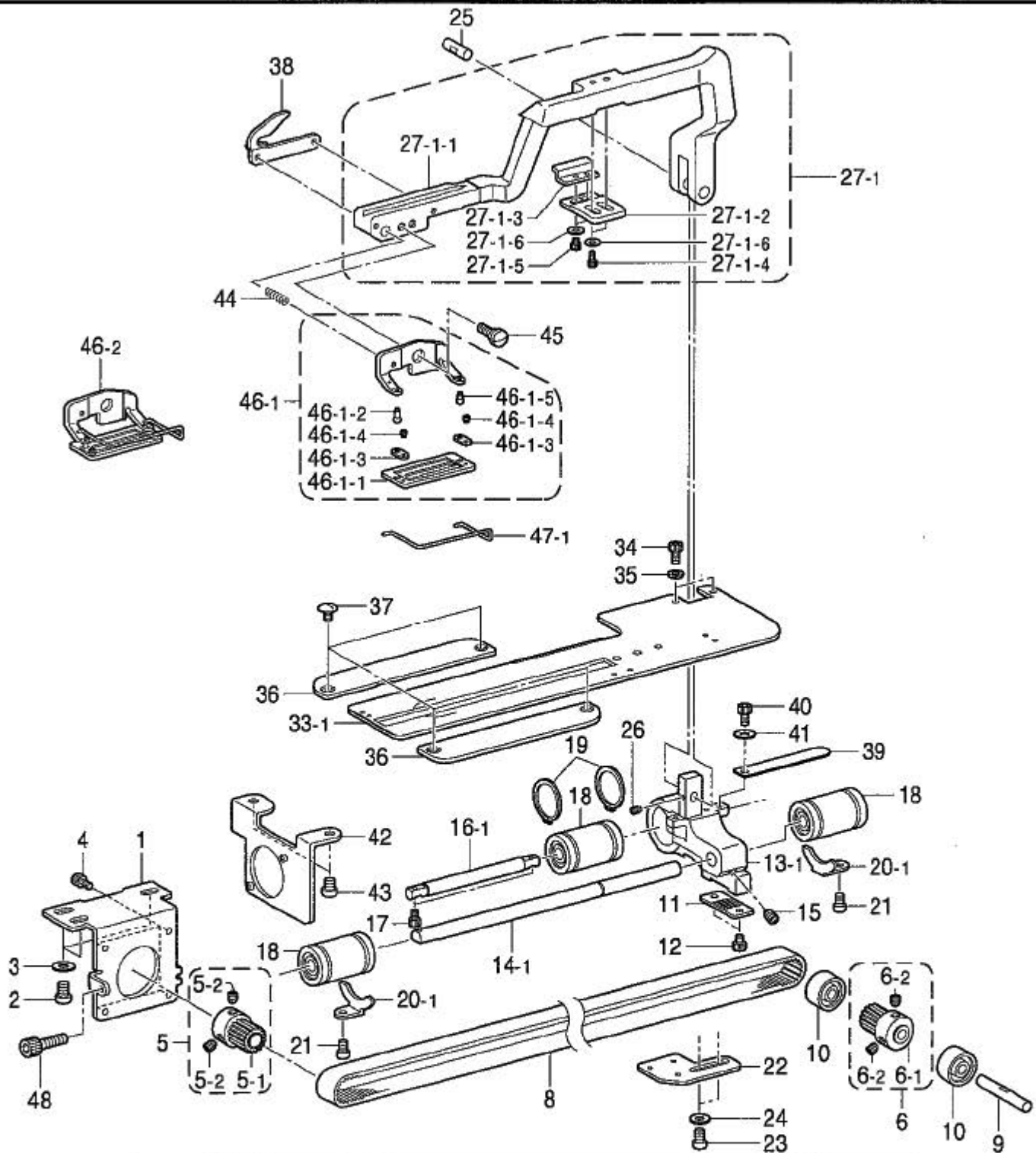

G1.送り関係 (-2,-3)/ Feed mechanism(For "-2 & -3")

REF.NO	CODE	QTY	ヒンメイ	NAME OF PARTS	RM
46-1-4	107404001	2	シメネジ 1.98	SCREW, SM1.98-64X2	
46-1-5	159927001	1	ヌツカミササビピン S	PIN, S	
46-2	S37100101	1	ヌツカミ25RSクミ	WORK CLAMP ASSY, 25RS W/F-G	
			<-3用>	<For "-3">	
46-3	S01467201	1	ニツヨクヌツカミ25クミ	WORK CLAMP ASSY, 25-K	
46-3-1	144630001	1	ニツヨクヌツカミ	WORK CLAMP, 25-K	
46-3-2	159926001	1	ヌツカミササビピン L	PIN, L	
46-3-3	144707001	2	ヌツカミササビイタハネ	SPRING, PLATE	
46-3-4	107404001	2	シメネジ 1.98	SCREW, SM1.98-64X2	
46-3-5	159927001	1	ヌツカミササビピン S	PIN, S	
46-4	S37102101	1	ニツヨクヌツカミ25クミ	WORK CLAMP ASSY, 25-K W/F-G	
			<-2用、-3用>	<For "-2 & -3">	
47-1	159080000	1	フィンガードM	FINGER GUARD, M	
48	018502022	1	ボルトM5X20	BOLT, SOCKET M5X20	

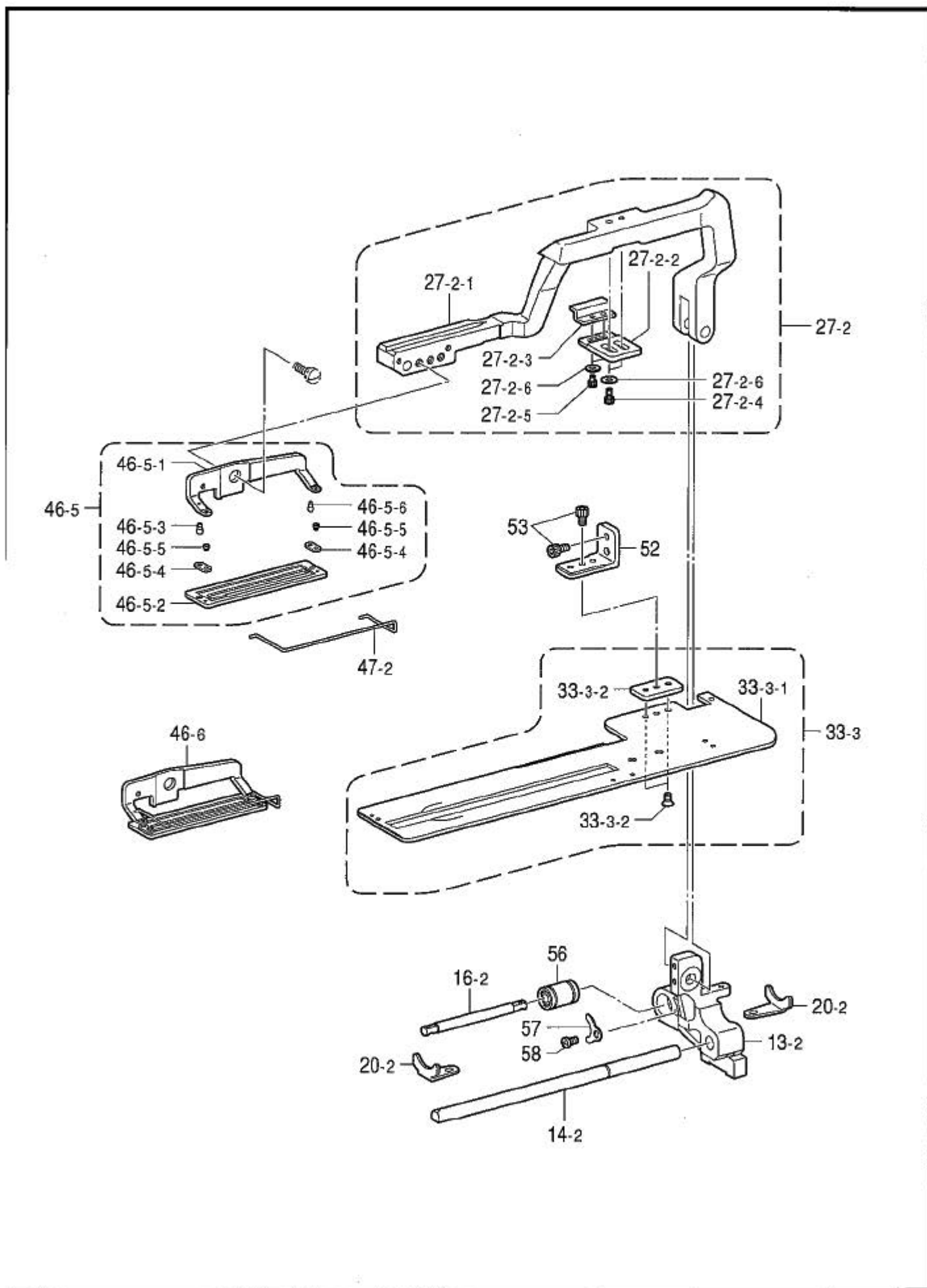

G2.送り関係 (-5)/ Feed mechanism(For "-5")

REF.NO	CODE	QTY	ヒンメイ	NAME OF PARTS	RM
			<-5用>	<For "-5">	
13-2	S54508001	1	オクリウテ`ササIタイ-5	FEED ARM SUPPORT, -5	
14-2	S54512001	1	オクリアンナイ`クB-5	SHAFT, B-5 ;F-GUIDE	
16-2	S54511001	1	オクリアンナイ`クA-5	SHAFT, A-5 ;F-GUIDE	
20-2	S54513001	2	タマシ`クウケトメイ`B	STOPPER PLATE, B ;B-BEARING	
27-2	S54502101	1	オクリウテ`クミ-5	FEED ARM ASSY, 5	
27-2-1	S54503001	1	オクリウテ`-5	FEED ARM, 5	
27-2-2	S50218001	1	ニカ`シカムササIイ	SUPPORT PLATE	
27-2-3	S50219101	1	ウウイトキリニカ`シカム	CAM	
27-2-4	018681022	2	アサホ`ネト4.37X10	BOLT, SOCKET SM4.37X10	
27-2-5	018680522	2	アサホ`ネト4.37X5	BOLT, SOCKET SM4.37X5	
27-2-6	110735002	4	サ`カ`ネ	WASHER	
33-3	S54504001	1	カ`サオクリイテ-5クミ	LENGTH FEED PLATE ASSY, -5	
33-3-1	S54505001	1	カ`サオクリイテ-5	LENGTH FEED PLATE, -5	
33-3-2	S54506001	1	オクリイタスハ`-サ	SPACER, ;FEED PLATE	
33-3-3	117160001	2	サラネシ`4.37	SCREW, FLAT SM4.37	
46-5	S54514101	1	ヌノツカミ70クミ	WORK CLAMP ASSY, 70	
46-5-1	S54516101	1	ヌノツカミササI	WORK CLAMP HOLDER	
46-5-2	S54515001	1	ヌノツカミ70	WORK CLAMP, 70	
46-5-3	159926001	1	ヌノツカミササIピン L	PIN, L	
46-5-4	107401001	2	ヌノツカミササIイタハ`ネ	SPRING, PLATE	
46-5-5	107404001	2	シメネシ`1.98	SCREW, SM1.98-64X2	
46-5-6	S54987001	1	ヌノツカミササIピン F	PIN, F	
46-6	S54518101	1	ヌノツカミ70クミF	WORK CLAMP ASSY, 70 W/F-G	
47-2	S54517000	1	フィンガ`-カ`-ト`70	FINGER GUARD, 70	
52	S54507001	1	オクリイタササIイ	FEED PLATE SUPPORT	
53	018680822	2	アサホ`ネト4.37X8	BOLT, SOCKET SM4.37X8	
56	S54509000	1	リニアブ`ツシ19.53	LINEAR BUSH, 9.53	
57	S54510001	1	リニアブ`ツシ10メイ	STOPPER PLATE, L-BUSH	
58	062680612	1	サハ`コ4.37-40X6	SCREW, PAN SM4.37-40X6	

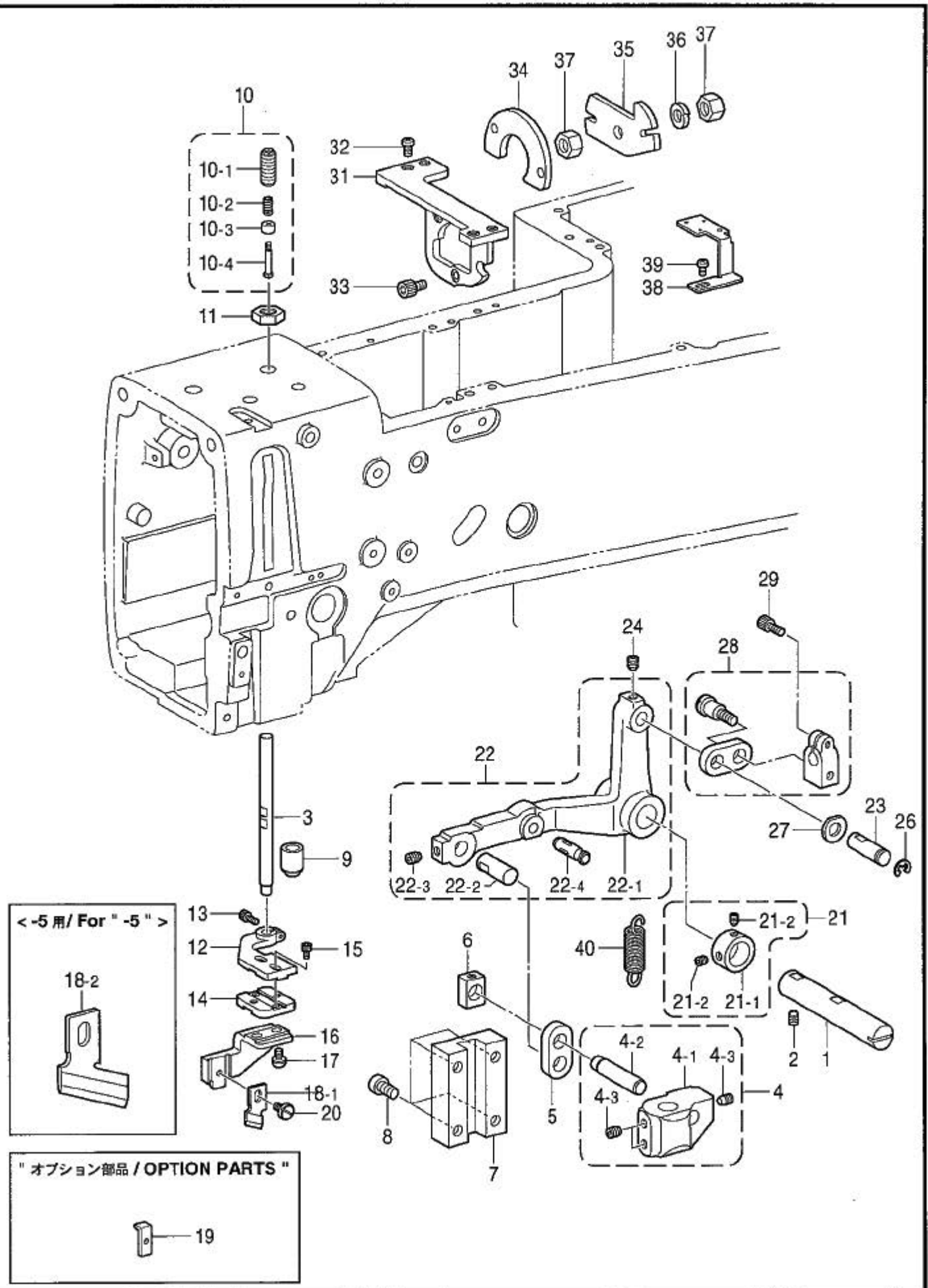

H.カッター関係 / Cutter mechanism

REF.NO	CODE	QTY	ヒンメイ	NAME OF PARTS	RM
1	S50283001	1	カッタークトウテシク	CUTTER DRIVING ARM SHAFT	
2	014760622	1	アトメネシ 5.95	SET SCREW, SOCKET SM5.95	
3	S50284001	1	カッターサウシク	CUTTER DRIVING SHAFT	
4	S50285001	1	サウシクホルダクミ	DRIVING SHAFT HOLDER ASSY	
4-1	S50286001	1	カッターサウシクホルダ	CUTTER DRIVING SHAFT HOLDER	
4-2	S50287001	1	カッターサウシクリンク	CUTTER DRIVING LINK SHAFT	
4-3	014780622	3	アトメネシ 6.35ホミ	SET SCREW, SOCKET (CP) SM6.35	
5	S50288001	1	カッタークトウリンク	CUTTER DRIVING LINK	
6	102630001	1	ハコアンナイカクマ	SLIDE BLOCK, N-BAR GUIDE	
7	S50120001	1	カッターホアンナイ	GUIDE, ;C-BAR	
8	062761012	4	ナコ 5.95-28X10	SCREW, PAN SM5.95-28X10	
9	159117001	1	カッターサウシクメタル	BUSH, ;C-DRIVING SHAFT	
10	S50289001	1	チヨウセツネシクミ	ADJUSTING SCREW ASSY	
10-1	S50290001	1	チヨウセツネシ	ADJUSTING SCREW	
10-2	S50291001	1	クツシヨシハネ	SPRING, COMPRESSION	
10-3	S50292001	1	クツシヨシウケ	CUSHION SUPPORT	
10-4	S50293001	1	タンネシ 3.57	SHOULDER SCREW, SM3.57	
11	021910302	1	ナツトシ 12.70	NUT, 3 SM12.70	
12	S50294001	1	カッターホルダ	CUTTER HOLDER	
13	018681022	1	アホホ 4.37X10	BOLT, SOCKET SM4.37X10	
14	S50295001	1	カッターホルダM	CUTTER HOLDER, M	
15	018680632	2	アホホ 4.37X6	BOLT, SOCKET SM4.37X6	
16	S50296001	1	カッターホルダDL	CUTTER HOLDER, DL	
17	153057102	2	オクリイタシメネシ	SCREW, ROUND W/SOCKET SM4.37	
18-1	S51352001	1	<-2用、-3用> カッター1/2	<For "-2 & -3"> CUTTER, 1/2	
18-2	S51358001	1	<-5用> カッター1	<For "-5"> CUTTER, 1	
19	S50297001	1	"オプション部品" カッターホルダ	"OPTION PARTS" CUTTER HOLDER	
20	115503001	1	シメネシ 4.37	SCREW, SM4.37	
21	S41466001	1	オクリシクセツカクミ	SET SCREW COLLAR ASSY	
21-1	S09212001	1	セツカク	SET SCREW COLLAR	
21-2	014770622	2	アトメネシ 6.35ホミ	SET SCREW, SOCKET (CP) SM6.35	
22	S50298101	1	カッタークトウテシク	CUTTER DRIVING ARM ASSY	
22-1	S50299101	1	カッタークトウテ	CUTTER DRIVING ARM	
22-2	159104001	1	ピン	PIN	
22-3	014680622	1	アトメネシ 4.37ホミ	SET SCREW, SOCKET (CP) SM4.37	
22-4	159379001	1	ピン、ドワ 6X18	PIN, DOWEL BX6X18	
23	S50300001	1	カッターリンクシク	CUTTER LINK SHAFT	
24	014760622	1	アトメネシ 5.95	SET SCREW, SOCKET SM5.95	
26	048060342	1	リングE6	RETAINING RING, E6	
27	110367001	1	ワッシャ	WASHER, PLAIN SPECIAL 8	
28	S51162001	1	カッターリンクイキ	CUTTER LINK BRACKET ASSY	
29	018681232	1	アホホ 4.37-40X12	BOLT, SOCKET SM4.37-40X12	
31	S50362001	1	カッターソレノイト	CUTTER SOLENOID BRACKET	
32	062711412	4	ナコ 4.76-32X14	SCREW, PAN SM4.76-32X14	
33	018501022	3	アホホ 5X10	BOLT, SOCKET M5X10	
34	S50363000	1	ストップクッション	STOPPER CUSHION	
35	S50364001	1	ソレノイト	STOPPER, ;SOL.	
36	028080242	1	ワッシャ、スプリング 2-8	WASHER, SPRING 2-8	
37	021080202	2	ナツトシ M8	NUT, 2 M8	
38	S50365101	1	カッターセンサトリツキ	SETTING PLATE, C-SENSOR	
39	062710812	1	ナコ 4.76-32X8	SCREW, PAN SM4.76-32X8	
40	S50366001	1	カッターモトシハネ	SPRING	

J. 糸切れ感知関係 / Thread breakage detector mechanism

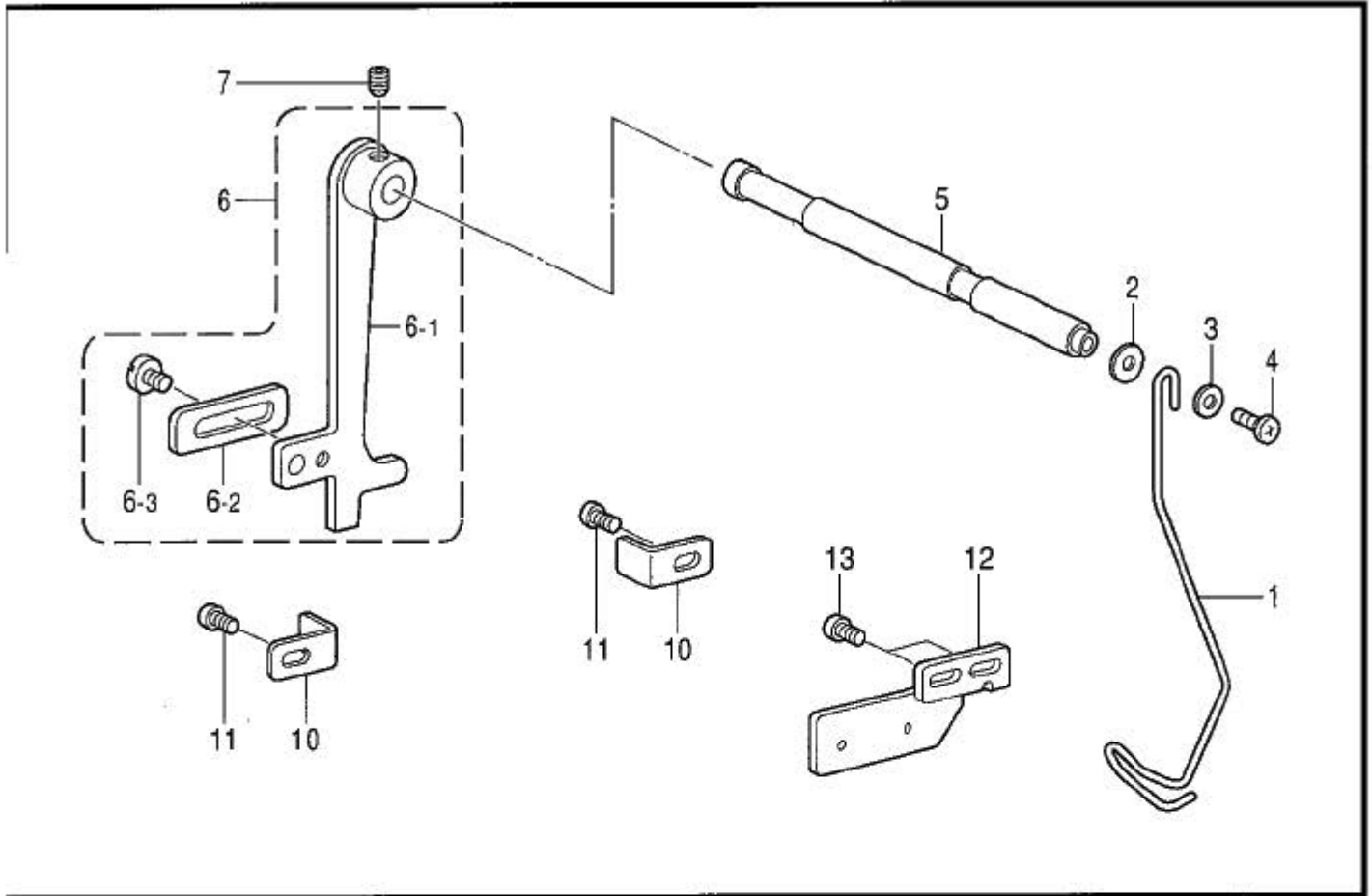

118-H80-219

K. 下軸関係 / Lower shaft mechanism

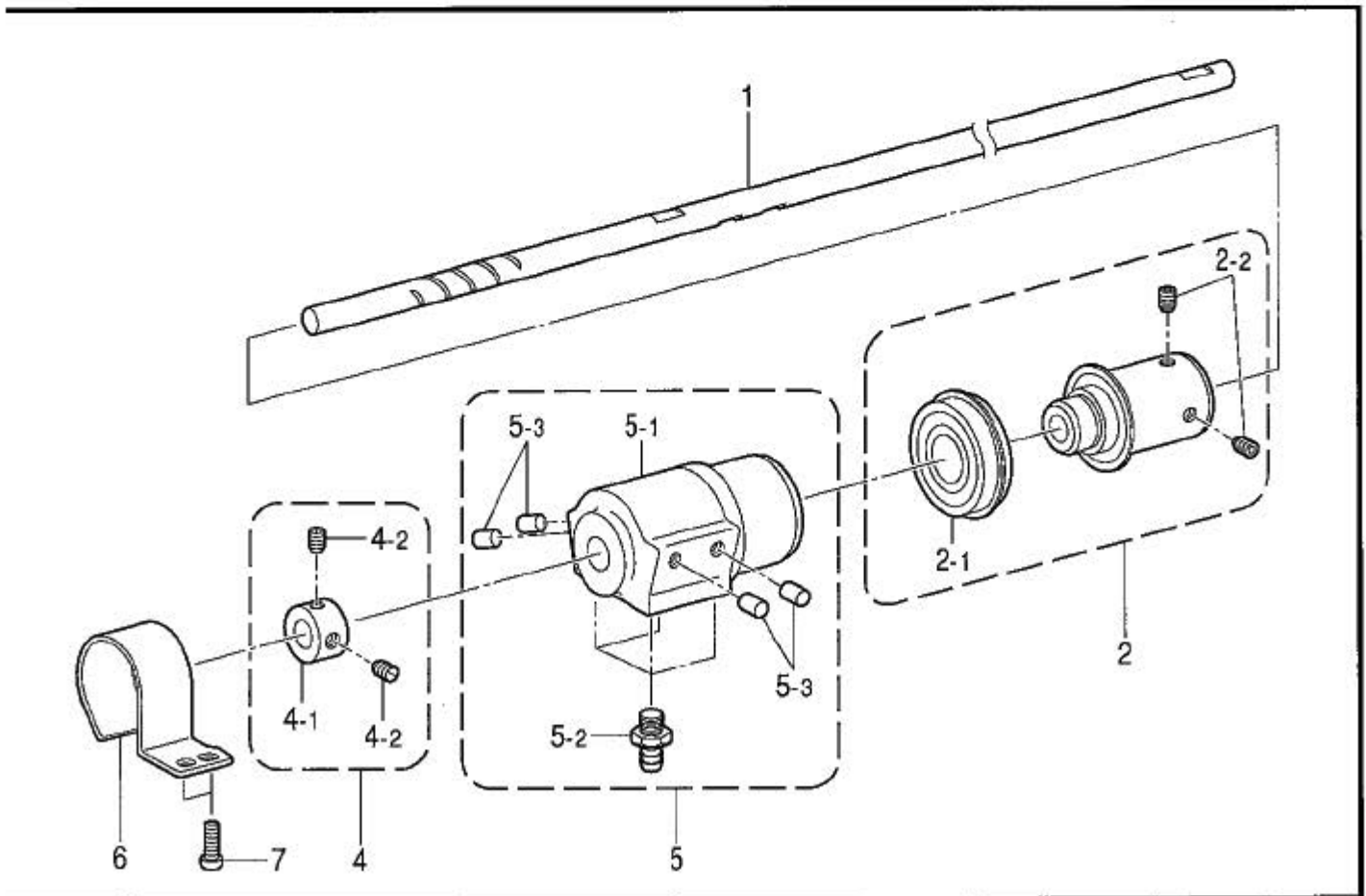

118-H80-305

J.糸切れ感知関係 / Thread breakage detector mechanism

REF.NO	CODE	QTY	ヒンメイ	NAME OF PARTS	RM
1	S50273000	1	トキレカンチトアンナイ	THREAD GUIDE	
2	025060232	1	ヒラサ ^カ ネチユ6	WASHER, PLAIN M 6	
3	025350332	1	ヒラサ ^カ ネチ ^イ 3.5	WASHER, PLAIN L 3.5	
4	060670612	1	ハ ^イ ント ^ス 357-40X6	SCREW, BIND SM3.57-40X6	
5	159145001	1	トキレカンチレハ ^シ ク	SHAFT, ;TR-BREAKAGE PERCEIVING	
6	S51173001	1	カツタオチホ ^ウ シイタクミ	CUTTER BAR FIXED PLATE ASSY	
6-1	141619001	1	カツタオチホ ^ウ シイ	FIXEING PLATE, ;C-BAR	
6-2	141620001	1	ホ ^ウ シイタハ ^ラ ンス	BALANCER	
6-3	101671002	1	シメネジ ⁴ .37	SCREW, SM4.37	
7	014760622	1	アトメネジ ⁵ .95	SET SCREW, SOCKET SM5.95	
10	S50274001	2	レハ ^ス トツハ ^レ	LEVER STOPPER	
11	062400612	2	ナ ^ハ コ ^ス 4X6	SCREW, PAN M4X6	
12	S50275001	1	トキレカンチセンサイ	PLATE, ;TR-BREAKAGE SENSOR	
13	062400612	1	ナ ^ハ コ ^ス 4X6	SCREW, PAN M4X6	

118-H80-219

K.下軸関係 / Lower shaft mechanism

REF.NO	CODE	QTY	ヒンメイ	NAME OF PARTS	RM
1	S50240001	1	シタシ ^ク	LOWER SHAFT	
2	S50241001	1	タイミンク ^フ ーリクミ	TIMMING PULLEY ASSY	
2-1	076002450	1	タマシ ^ク ウケ6002DD	BALL BEARING, 6002DD	
2-2	014760622	2	アトメネジ ⁵ .95	SET SCREW, SOCKET SM5.95	
4	183827001	1	セツトカラ ^ク ミ	SET SCREW COLLAR ASSY	
4-1	104521001	1	セツトカラ ^レ	SET SCREW COLLAR	
4-2	014770622	2	アトメネジ ⁶ .35 ^ホ ミ	SET SCREW, SOCKET (CP) SM6.35	
5	S50243001	1	シタシ ^ク メタル ^ク ミ	BUSH ASSY, M	
5-1	S50244001	1	シタシ ^ク メタル ^レ	BUSH, M	
5-2	S38735001	4	オイル ^ク チ	OIL FEEDING PIPE	
5-3	142274101	4	ゴ ^ム セン4.2	RUBBER CAP, 4.2	
6	S50245001	1	シタシ ^ク メタル ^カ ハ ^レ	COVER	
7	062670612	2	ナ ^ハ コ ^ス 357-40X6	SCREW, PAN SM3.57-40X6	

118-H80-305

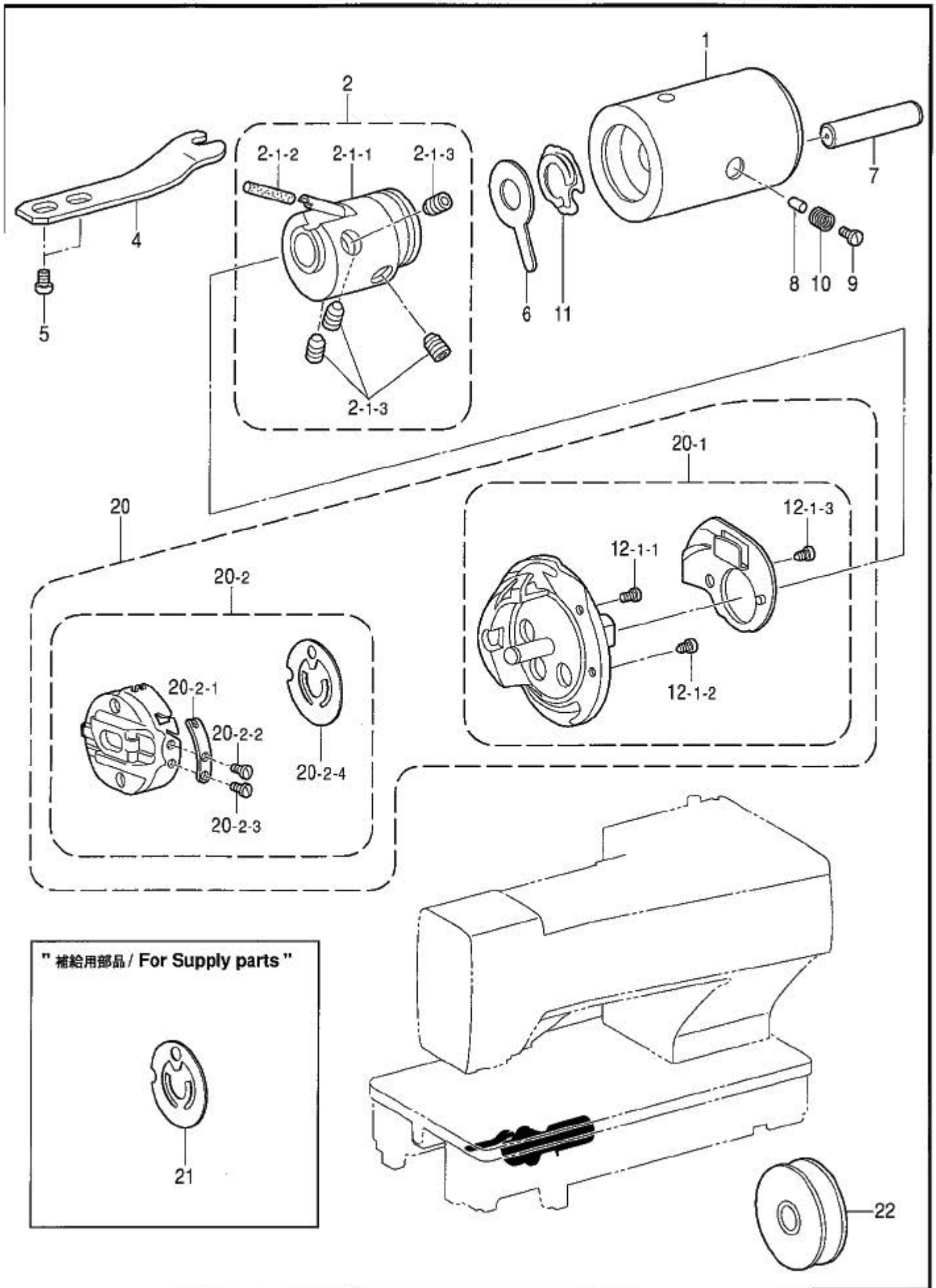

L. カマ関係 / Rotary hook mechanism

REF.NO	CODE	QTY	ヒンメイ	NAME OF PARTS	RM
1	S50226001	1	カマシ`クメタル	BUSH	
2	S51226001	1	カマツキ`テソウクミ	ROTARY HOOK JOINT SET	
2-1	S50227001	1	カマツキ`テクミ	JOINT ASSY, ;R-HOOK	
2-1-1	S50228001	1	カマツキ`テ	JOINT, ;R-HOOK	
2-1-2	S50229000	1	フィルト	FELT	
2-1-3	014760622	4	アサトメネシ`5.95	SET SCREW, SOCKET SM5.95	
4	S50230001	1	カマトメ	B-CASE HOLDER POSITION BRACKET	
5	100644005	2	シメネシ`4.37	SCREW, SM4.37	
6	S50232000	1	カマフィルト	FELT	
7	S50231100	1	トウシシカテー	COLLAR	
8	S07478000	1	ゴムオサエ	RUBBER PRESSER	
9	S54741001	1	シメネシ`6.35	SCREW, SM6.35	
10	S50233001	1	ゴムオサエハ`ネ	SPRING	
11	S50111000	1	フィルトオサエハ`ネ	SPRING	
20	S50234901	1	カマホ`ビ`ンケースハコクミ	R-HOOK & B-CASE ASSY, W/BOX	
20-1	S50235901	1	カマハコクミ	ROTARY HOOK ASSY, W/BOX	
20-1-1	183526001	2	ナカカマオサエシメネシ`	SCREW	
20-1-2	S50236001	1	ナカカマオサエシメネシ`B	SCREW	
20-1-3	183598001	1	ウライタシメネシ`	SCREW	
20-2	S50237001	1	ホ`ビ`ンケースクミ	BOBBIN CASE ASSY	
20-2-1	S09477001	1	ホ`ビ`ンチヨウシハ`ネ	SPRING	
20-2-2	180721001	1	チヨウシハ`ネシメネシ`	SCREW	
20-2-3	183507001	1	チヨウシネシ`	ADJUSTING SCREW	
20-2-4	S50239001	1	ホ`ビ`ンオサエハ`ネ	SPRING, ANTI-SPIN	
22	159158051	1	ホ`ビ`ン	BOBBIN	
21	S50239001	1	” 補給部品 ” ホ`ビ`ンオサエハ`ネ	”For Supply parts” SPRING, ANTI-SPIN	

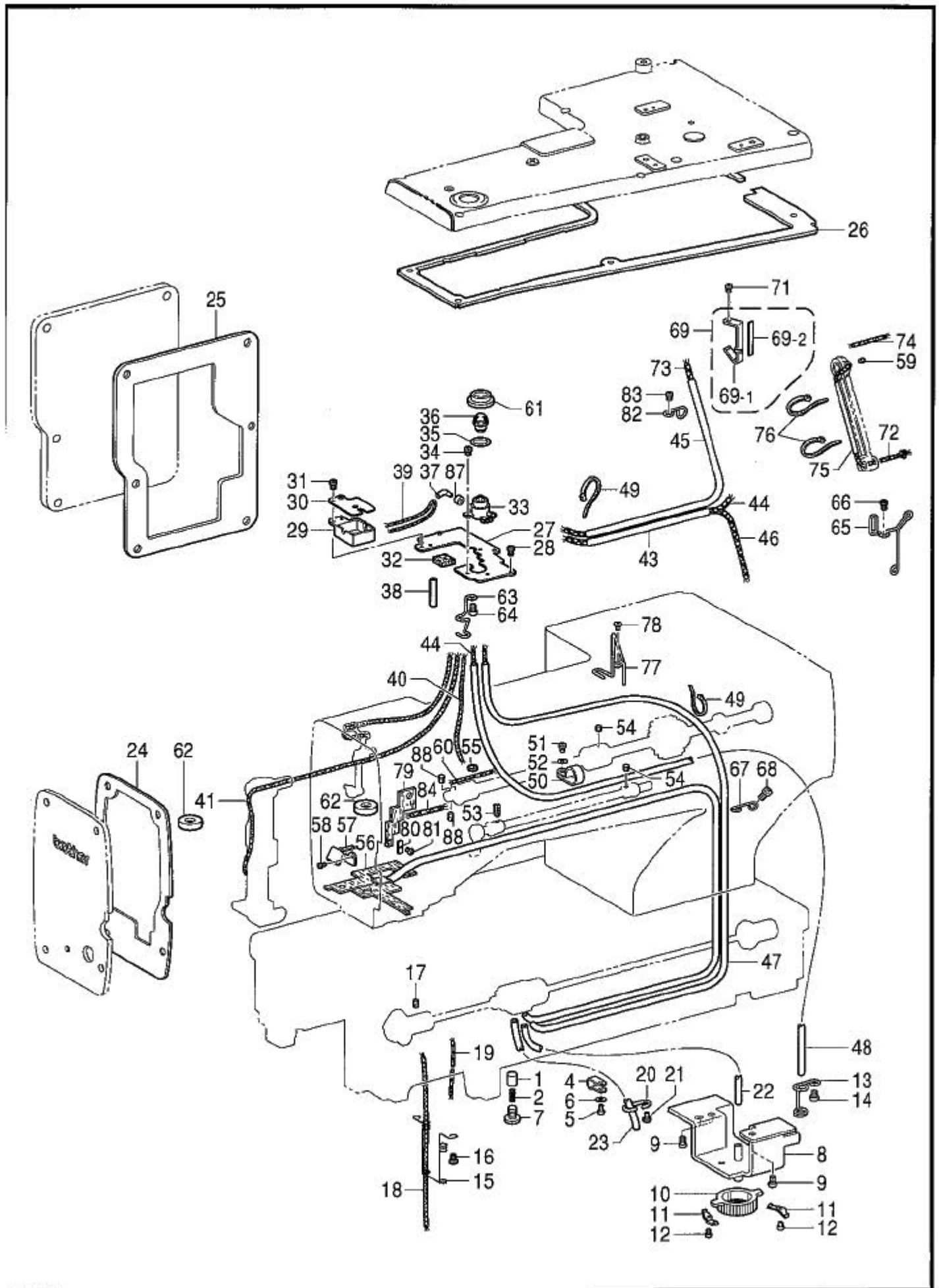

REF.NO	CODE	Q'TY	ヒンメイ	NAME OF PARTS	RM
1	144875001	2	ﾌﾞﾗﾝｼﾞﾝｸﾞﾔｰ	PLUNGER	
2	S52764001	2	ﾌﾞﾗﾝｼﾞﾝｸﾞﾔｰﾊﾞﾈ	SPRING, COMPRESSION	
4	552907000	2	ｺｰﾄﾞﾎﾙﾀﾞｰ#10	CORD HOLDER, 10N	
5	062670612	2	ﾈﾊﾞｺ357-40X6	SCREW, PAN SM3.57-40X6	
6	025350132	2	ﾋﾗｻﾞｶﾞﾈｼﾞｮｳ	WASHER, PLAIN S 3.5	
7	112467002	2	ｼﾒﾈｼﾞ6.35	SCREW, SM6.35X5	
8	S50356001	1	ｵｲﾙﾌｲﾙﾀﾞﾄﾘｯｸｲﾀｸﾐ	OIL FILTER BRACKET ASSY	
9	062680812	3	ﾈﾊﾞｺ437-40X8	SCREW, PAN SM4.37-40X8	
10	144872101	1	ﾌﾟﾝﾌﾟﾌｲﾙﾀｰ	PUMP FILTER	
11	144874001	2	ﾌｲﾙﾀｰﾊﾞﾈ	SPRING	
12	062670512	2	ﾈﾊﾞｺ357-40X5	SCREW, PAN SM3.57-40X5	
13	S50359001	1	ﾁｭｰﾌﾞｻｻｲD	TUBE SUPPORT, D	
14	062680612	1	ﾈﾊﾞｺ4.37-40X6	SCREW, PAN SM4.37-40X6	
15	S50360001	1	ｶﾞﾌﾞﾙﾌｪﾙﾄｻｻｲ	FELT SUPPORT	
16	060670612	2	ﾊﾞｲﾝﾄﾞ357-40X6	SCREW, BIND SM3.57-40X6	
17	S50556000	1	ﾌｪﾙﾄ	FELT	
18	S50563000	1	ｸﾐﾋｷ4X200	WICK, 4X200	
19	S50564000	1	ｸﾐﾋｷ2X300	WICK, 2X150	
20	S50559001	1	ﾁｭｰﾌﾞｻｻｲ	TUBE SUPPORT	
21	060670612	1	ﾊﾞｲﾝﾄﾞ357-40X6	SCREW, BIND SM3.57-40X6	
22	S50557000	1	ﾋﾞﾆﾙﾁｭｰﾌﾞ	OIL TUBE	
23	S50558000	1	ﾋﾞﾆﾙﾁｭｰﾌﾞ	OIL TUBE, L=180	
24	S50513000	1	ﾏﾝｲﾀﾊﾞｯｷﾝ	PACKING, ;F-PLATE	
25	S50514000	1	ｶﾞﾌﾞﾙﾀﾊﾞｯｷﾝ	PACKING, ;R-COVER	
26	S50515000	1	ｸﾞｯﾌﾞﾀﾊﾞｯｷﾝ	PACKING, ;T-COVER	
27	S50516001	1	ﾄﾞﾗｲﾝｸﾞﾊﾞｰｽｻｻｲ	WICK BASE SUPPORT	
28	062670612	2	ﾈﾊﾞｺ357-40X6	SCREW, PAN SM3.57-40X6	
29	159187000	1	ﾄﾞﾗｲﾝｸﾞﾊﾞｰｽA	FELT BASE, A	
30	S50517001	1	ﾄﾞﾗｲﾝｸﾞﾊﾞｰｽﾌﾀ	CAP	
31	062680712	2	ﾈﾊﾞｺ437-40X7	SCREW, PAN SM4.37-40X7	
32	S50518000	1	ﾄﾞﾗｲﾝｸﾞﾊﾞｰｽﾌｪﾙﾄ	FELT	
33	S50519000	1	ｵｲﾙﾀｰﾐﾅﾙ	OIL TERMINAL	
34	062680612	2	ﾈﾊﾞｺ4.37-40X6	SCREW, PAN SM4.37-40X6	
35	S50520000	1	ﾊﾞｯｷﾝ	PACKING	
36	S50521000	1	ｵｲﾙﾏﾄﾞ	OIL CAP	
37	159193000	1	ｵｲﾙﾊﾟｲﾌﾟB	OIL PIPE, B	
38	S50522000	1	ﾋﾞﾆﾙﾁｭｰﾌﾞ	OIL TUBE	
39	S52763000	1	ｸﾐﾋｷ2X140	WICK, 2X140	
40	S50524000	1	ｸﾐﾋｷ3X160	WICK, 3X160	
41	S50525000	1	ｸﾐﾋｷ3X290	WICK, 3X290	
43	S50527000	1	ﾋﾞﾆﾙﾁｭｰﾌﾞ	OIL TUBE	
44	S50528000	1	ｸﾐﾋｷ3X280	WICK, 3X280	
45	S50529000	1	ﾋﾞﾆﾙﾁｭｰﾌﾞ	OIL TUBE, L=320	
46	S50530000	1	ｸﾐﾋｷ3X355	WICK, 3X355	
47	S50531000	1	ﾋﾞﾆﾙﾁｭｰﾌﾞ	OIL TUBE	
48	S50532000	1	ﾋﾞﾆﾙﾁｭｰﾌﾞ	OIL TUBE	
49	228475000	2	ｸﾞｯﾌﾞﾀﾞﾝﾄﾞ1.9X80	FASTENING BAND, 1.9X80	
50	S00480000	1	ｺｰﾄﾞﾎﾙﾀﾞｰ#5	CORD HOLDER, 5N	
51	062670612	1	ﾈﾊﾞｺ357-40X6	SCREW, PAN SM3.57-40X6	
52	025350132	1	ﾋﾗｻﾞｶﾞﾈｼﾞｮｳ	WASHER, PLAIN S 3.5	
53	106436001	1	ﾌｪﾙﾄ	FELT	
54	107149001	2	ﾌｪﾙﾄ	FELT	
55	151927001	1	ｸﾗｯﾁﾌｪﾙﾄ	FELT, ;CLUTCH	
56	S50533000	1	ｽｲｱｸﾞﾁｭｰﾌﾞｸﾐ	OIL TUBE ASSY	
57	S50536001	1	ﾌｪﾙﾄｻｻｲ	FELT HOLDER	
58	062670512	1	ﾈﾊﾞｺ357-40X5	SCREW, PAN SM3.57-40X5	
59	S25328001	1	ﾌｪﾙﾄ	FELT	
60	S50537000	1	ｸﾐﾋｷ4X50	WICK, 4X50	
61	S50538001	1	ｵｲﾙﾜﾝﾄﾞｻｻｲ	OIL WINDOW SUPPORT	
62	S50539000	2	ｵｲﾙﾘｼﾞｸﾀ	OIL REJECTOR	
63	S50540001	1	ﾁｭｰﾌﾞｻｻｲ	TUBE SUPPORT	

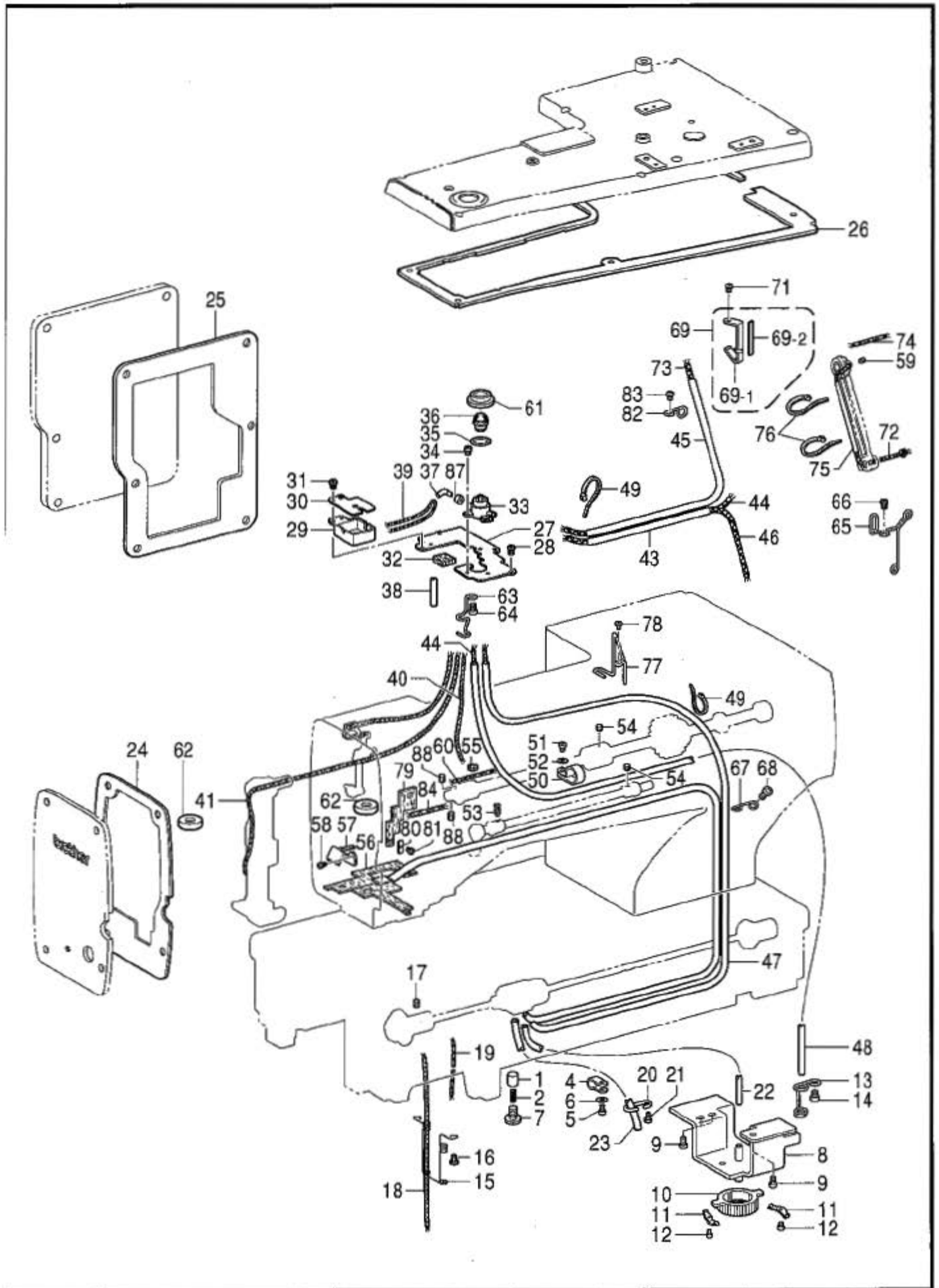

M.給油潤滑関係 / Lubrication

REF.NO	CODE	Q'TY	品名	NAME OF PARTS	RM
64	062680612	1	ナット 3.37-40X6	SCREW, PAN SM4.37-40X6	
65	S50541001	1	チューブ ササIU	TUBE SUPPORT, U	
66	062670512	1	ナット 3.57-40X5	SCREW, PAN SM3.57-40X5	
67	S50542001	1	チューブ ササIM	TUBE SUPPORT, M	
68	062400612	1	ナット M4X6	SCREW, PAN M4X6	
69	S54763001	1	ハリフリフェルトササエカミ	FELT SUPPORT ASSY	
69-1	S50543001	1	ハリフリフェルトササエ	FELT SUPPORT	
69-2	S50544000	1	フェルト	FELT	
71	062400612	1	ナット M4X6	SCREW, PAN M4X6	
72	S50545000	1	クミヒモ3X180	WICK, 3X180	
73	S50546000	1	クミヒモ3X370	WICK, 3X370	
74	S50537000	1	クミヒモ4X50	WICK, 4X50	
75	S50547000	1	ヒールチューブ	OIL TUBE	
76	228475000	2	ケツソクバンド 1.9X80	FASTENING BAND, 1.9X80	
77	S50548001	1	ハリチューブ ササIR	TUBE SUPPORT, R	
78	060670612	1	バンド 3.57-40X6	SCREW, BIND SM3.57-40X6	
79	S50549000	1	クランクシャフトフェルト	FELT	
80	S50550001	1	フェルトササエ	FELT SUPPORT	
81	062670512	1	ナット 3.57-40X5	SCREW, PAN SM3.57-40X5	
82	S50551001	1	ハリフリチューブ ササI	TUBE SUPPORT	
83	002300603	1	ナット M3X6	SCREW, PAN M3X6	
84	S50552000	1	クミヒモ4X70	WICK, 4X70	
87	S51020000	1	トウシカラー	COLLAR	
88	S25328001	2	フェルト	FELT	

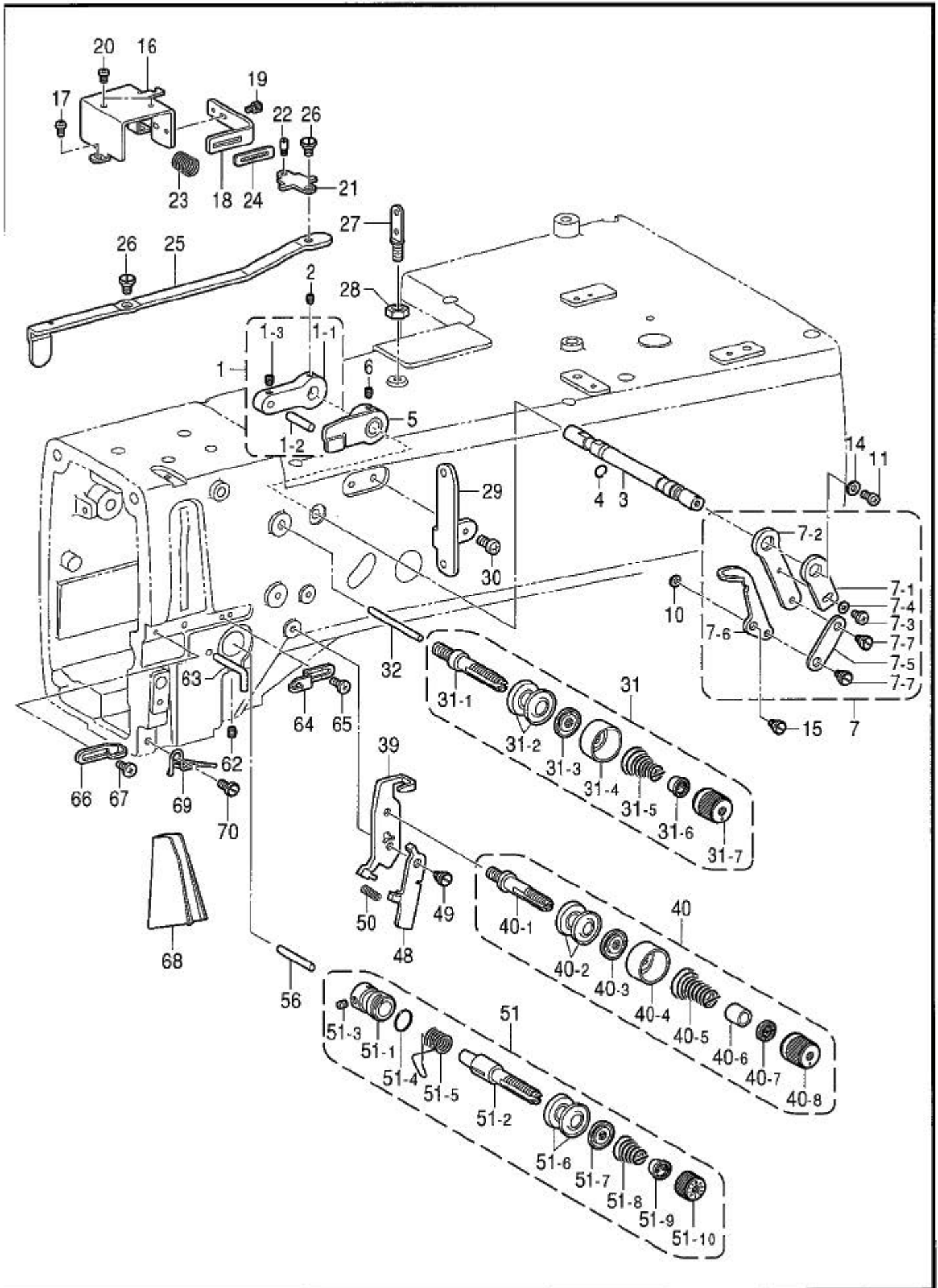

N.糸通シ関係 / Threading mechanism

REF.NO	CODE	Q'TY	ヒンメイ	NAME OF PARTS	RM
1	S50368001	1	イトユルメクトウレハークミ	T-RELEASE DRIVING LEVER ASSY	
1-1	S50369001	1	イトユルメクトウレハーク	TENSION RELEASE DRIVING LEVER	
1-2	S35095000	1	ニートルローラ4X13.8	NEEDLE ROLLER, 4X13.8	
1-3	014400432	1	アタクホミ4X4	SET SCREW, SOCKET (CP) M4X4	
2	014760622	1	アタメネジ5.95	SET SCREW, SOCKET SM5.95	
3	S50370001	1	イトユルメシク	TENSION RELEASE SHAFT	
4	081005070	1	OリングP5	O RING, P5	
5	S50371101	1	イトユルメカム	TENSION RELEASE CAM	
6	014760622	1	アタメネジ5.95	SET SCREW, SOCKET SM5.95	
7	S51185001	1	イトトリレハークミ	TENSION TAKE-UP LEVER ASSY	
7-1	S50372001	1	イトクリタシレハーク	LEVER	
7-2	S50373001	1	イトトリヨウセツレハーク	ADJUSTING LEVER	
7-3	060670512	1	ハイント357-40X5	SCREW, BIND SM3.57-40X5	
7-4	100645003	1	ザカネ	WASHER	
7-5	S50374001	1	イトトリレハークリンク	LEVER LINK	
7-6	S50375001	1	イトトリレハーク	TENSION TAKE-UP LEVER	
7-7	S50376001	2	ダンネジ4.37	SHOULDER SCREW, SM4.37	
10	100645003	1	ザカネ	WASHER	
11	062680612	1	ナハコ4.37-40X6	SCREW, PAN SM4.37-40X6	
14	025680234	1	ヒラザカネシヨウ4.37	WASHER, PLAIN S 4.37	
15	S50376001	1	ダンネジ4.37	SHOULDER SCREW, SM4.37	
16	S50377001	1	イトユルメソレノイトホルダ	SOLENOID HOLDER	
17	062670612	2	ナハコ357-40X6	SCREW, PAN SM3.57-40X6	
18	S50378001	1	プランジャオサエ	PLATE	
19	018300636	1	アホネM3X6	BOLT, SOCKET M3X6	
20	062300502	2	ナハコ3X5	SCREW, PAN M3X5	
21	S50379001	1	イトユルメソレノイトリンク	T-RELEASE SOLENOID LINK	
22	S25456001	1	プランジャピン	PLUNGER PIN	
23	S50380000	1	プランジャバネ	SPRING	
24	S50381000	1	オサエゴム	RUBBER	
25	S50382001	1	イトユルメリンク	TENSION RELEASE LINK	
26	S50376001	2	ダンネジ4.37	SHOULDER SCREW, SM4.37	
27	141590001	1	イトオシホウ	THREADING BAR, U	
28	150553003	1	ナツト5.95	NUT, SM5.95	
29	S50383001	1	イトカ	THREAD RETAINER	
30	062670612	2	ナハコ357-40X6	SCREW, PAN SM3.57-40X6	
31	S51184001	1	フイトヨウシクミ	SUB THREAD TENSION ASSY	
31-1	159219101	1	フイトヨウシホウ	SUB TENSION STUD	
31-2	145446001	2	イトヨウシラ	DISC, TENSION	
31-3	159805001	1	イトヨウシラオサエ	DISC PRESSER, TENSION	
31-4	144103009	1	イトヨウシラオサエ	DISC PRESSER, ;TENSION	
31-5	144110001	1	シタルハイトヨウシハネ	TENSION ADJUSTING SPRING	
31-6	S30564000	1	ヨウシハネウサカネ	WASHER	
31-7	S30565003	1	イトヨウシナツト	TENSION NUT, RED	
32	S50384101	1	イトユルメピン	TENSION RELEASE PIN	
39	S50385001	1	イトユルメレハーク	TENSION RELEASE LEVER BRACKET	
40	S51183001	1	イトヨウシホウクミ	TENSION STUD ASSY	
40-1	145440001	1	イトヨウシホウ	TENSION STUD	
40-2	145446001	2	イトヨウシラ	DISC, TENSION	
40-3	159805001	1	イトヨウシラオサエ	DISC PRESSER, TENSION	
40-4	144103009	1	イトヨウシラオサエ	DISC PRESSER, ;TENSION	
40-5	S50386001	1	イトヨウシハネ	TENSION SPRING	
40-6	S50387001	1	ヨウシナツトカ	COLLAR	
40-7	S12441001	1	ヨウシハネウサカネ	WASHER	
40-8	S30565005	1	イトヨウシナツト	TENSION NUT	
48	S50388001	1	イトユルメレハーク	TENSION RELEASE LEVER	
49	114988001	1	ダンネジ4.37	SHOULDER SCREW, M4.37	
50	S50389001	1	イトユルメレハーク	SPRING	
51	S51182101	1	イトヨウシホウウタクミ	TENSION STUD BRACKET ASSY	
51-1	S50390101	1	イトヨウシホウウタ	TENSION STUD BRACKET	
51-2	S50391001	1	イトヨウシホウ	TENSION STUD, L	

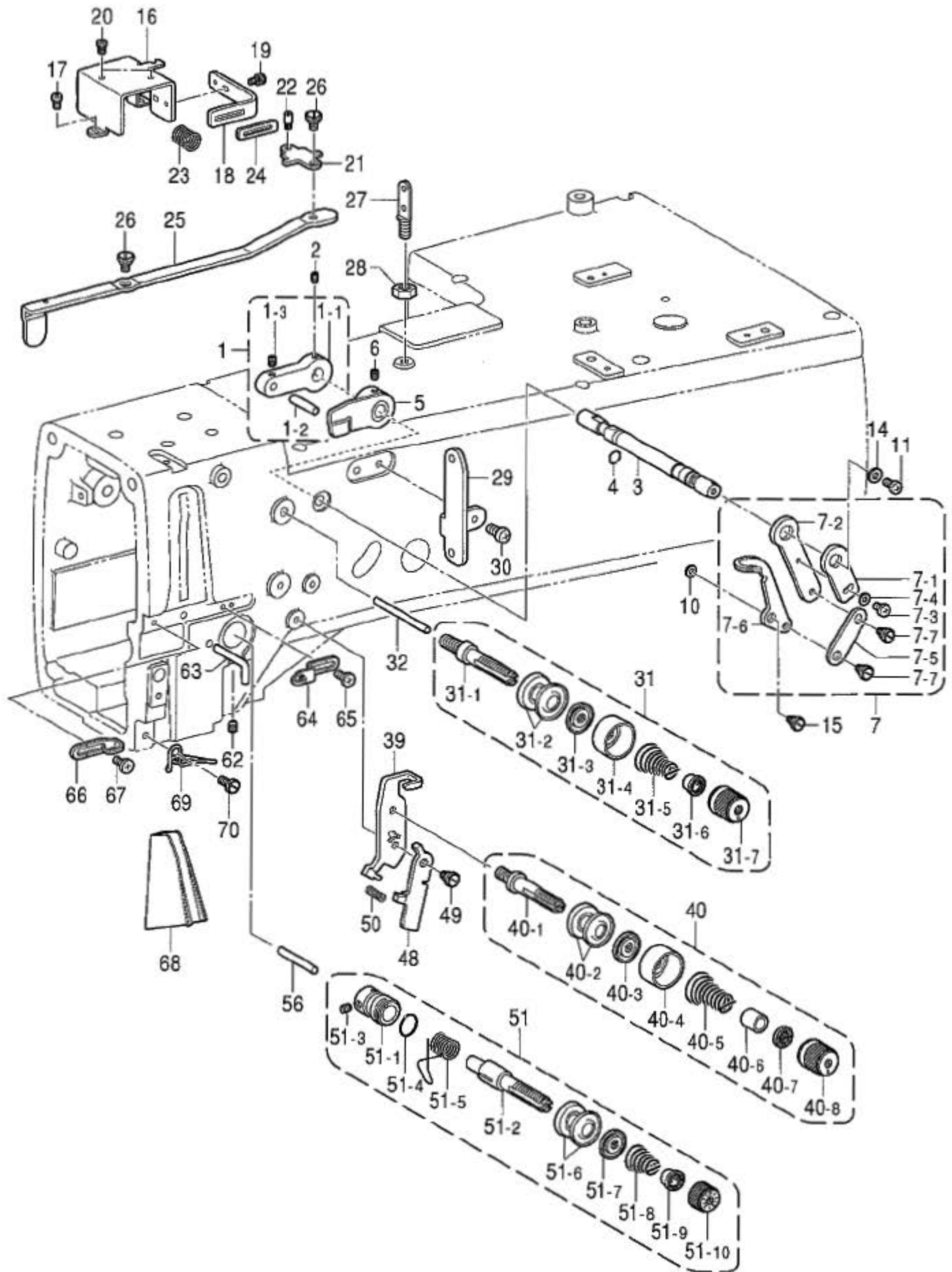

N.糸通シ関係 / Threading mechanism

REF.NO	CODE	QTY	ヒンメイ	NAME OF PARTS	RM
51-3	100402004	1	トメネジ 3.57	SET SCREW, SM3.57	
51-4	081014870	1	リング S14	O RING, S14	
51-5	145519001	1	糸トリハネ	THREAD TAKE-UP SPRING	
51-6	145446001	2	糸チヨウシナラ	DISC, TENSION	
51-7	159805001	1	糸チヨウシナラオサエ	DISC PRESSER, TENSION	
51-8	159221001	1	糸チヨウシハネ	TENSION SPRING	
51-9	S30564000	1	チヨウシハネウサガネ	WASHER	
51-10	S31032001	1	糸チヨウシナツト	TENSION NUT	
56	S50384101	1	糸ユルヒピン	TENSION RELEASE PIN	
62	S55975001	1	アトメネジ 5.95	SET SCREW, SOCKET SM5.95	
63	159224001	1	アームトカ	THREAD GUIDE, ARM	
64	S50392001	1	アームトアンナイ	THREAD GUIDE, ;ARM	
65	060670512	1	ハイント 357-40X5	SCREW, BIND SM3.57-40X5	
66	113316001	1	アームトアンナイ	THREAD GUIDE	
67	060670512	1	ハイント 357-40X5	SCREW, BIND SM3.57-40X5	
68	S50393000	1	糸トオシタ	THREADING PLATE	
69	159917201	1	アームトアンナイシタ	THREAD GUIDE, L ;ARM	
70	112751003	1	シメネジ 3.57	SCREW, SM3.57X7	
71	048060342	1	トメ7E6	RETAINING RING, E6	

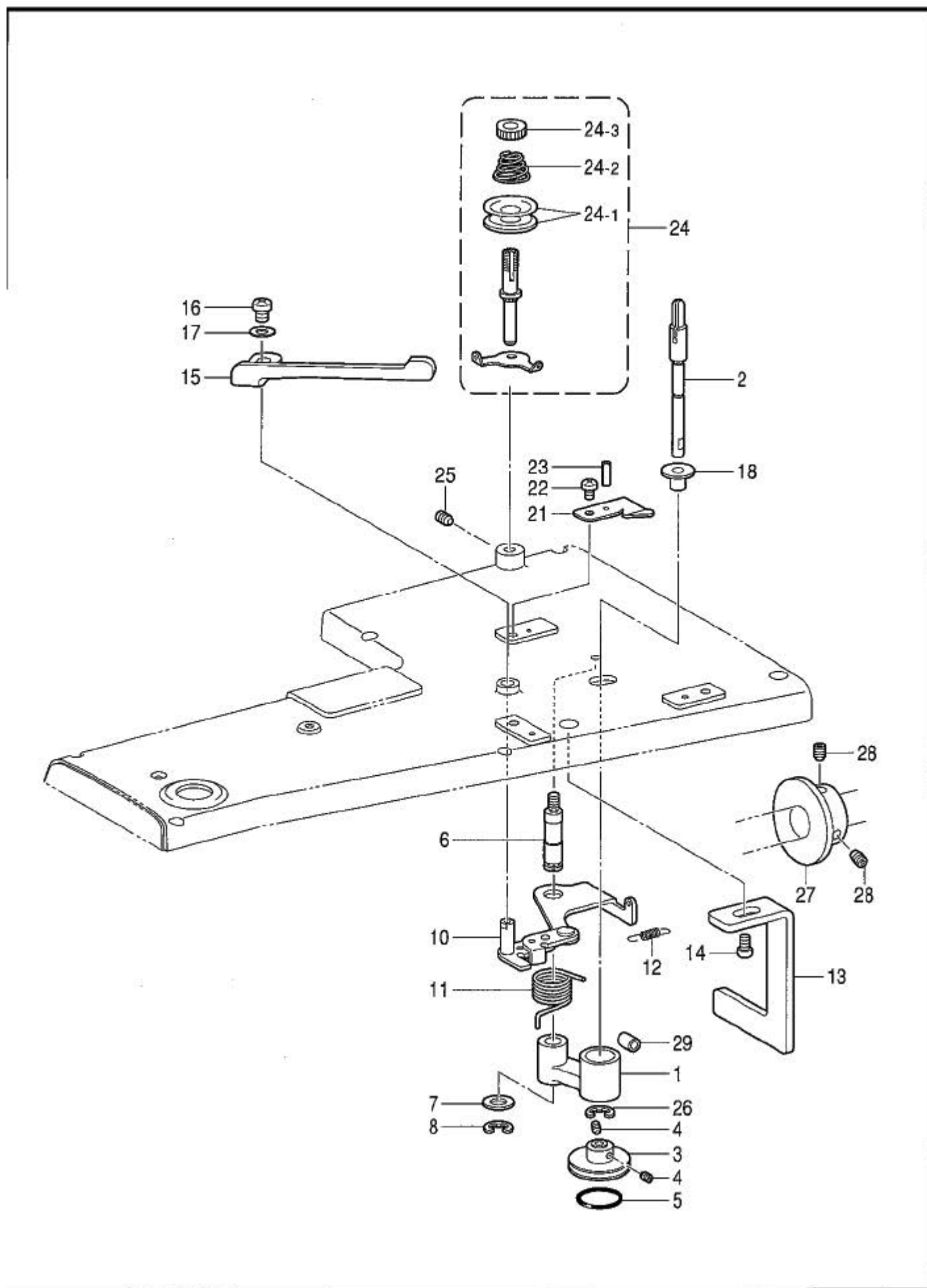

P.糸巻関係 / Bobbin winder mechanism

REF.NO	CODE	QTY	ヒンメイ	NAME OF PARTS	RM
1	S50276001	1	イトマキシ ^ク ウクミ	B-WINDER SHAFT BRACKET ASSY	
2	S50278001	1	イトマキシ ^ク	BOBBIN WINDER SHAFT	
3	S25410050	1	イトマキカルマ	BOBBIN WINDER WHEEL	
4	012400636	2	ア ^フ ヒラ4X6	SET SCREW, SOCKET (FT) M4X6	
5	S25789000	1	コム729	RUBBER RING, 29	
6	S50279001	1	イトマキウ ^テ シ ^ク	BOBBIN WINDER ARM SHAFT	
7	025080132	1	ヒラサ ^カ ネシヨウ8	WASHER, PLAIN S 8	
8	048060342	1	トメウE6	RETAINING RING, E6	
10	S25413101	1	ホ ^ヒ ンオサ ^シ クミ	BOBBIN PRESSER SHAFT ASSY	
11	S25417001	1	イトマキハ ^ネ	SPRING	
12	S25418101	1	イトマキト ^シ ハ ^ネ	SPRING	
13	S50280001	1	イトマキストッパ	BOBBIN WINDER STOPPER	
14	062400816	1	ハ ^コ 4X8	SCREW, PAN M4X8	
15	S25420051	1	ホ ^ヒ ンオサIR	BOBBIN PRESSER, R	
16	062400816	1	ハ ^コ 4X8	SCREW, PAN M4X8	
17	026040236	1	ヒラサ ^カ ネミカ ^キ 4	WASHER, PLAIN 4	
18	S10174000	1	ホコリヨケイタ	DUST GUARD PLATE	
21	157968001	1	ヌ	KNIFE	
22	062400616	1	ハ ^コ 4X6	SCREW, PAN M4X6	
23	047200642	1	ス ^ワ リンク ^ヒ ンAW2	PIN, SPRING ROLL AW2	
24	S38736101	1	イトマキイトチヨウシクミ	BOBBIN WINDER TENSION ASSY	
24-1	145446001	2	イトチヨウシカラ	DISC, TENSION	
24-2	115188001	1	シュイトチヨウシハ ^ネ	SPRING, TENSION	
24-3	108265009	1	イトチヨウシナツト	TENSION NUT	
25	012400636	1	ア ^フ ヒラ4X6	SET SCREW, SOCKET (FT) M4X6	
26	048040342	1	トメウE4	RETAINING RING, E4	
27	S50281000	1	イトマキプ ^ル	BOBBIN WINDER PULLEY	
28	014780622	2	ア ^フ トメネシ ^{6.35} ホ ^ミ	SET SCREW, SOCKET (CP) SM6.35	
29	S50282000	1	イトマキレハ ^ク ツシヨウ	B-WINDER LEVER CUSHION	

Q. 上糸切り関係 / Upper thread trimmer mechanism

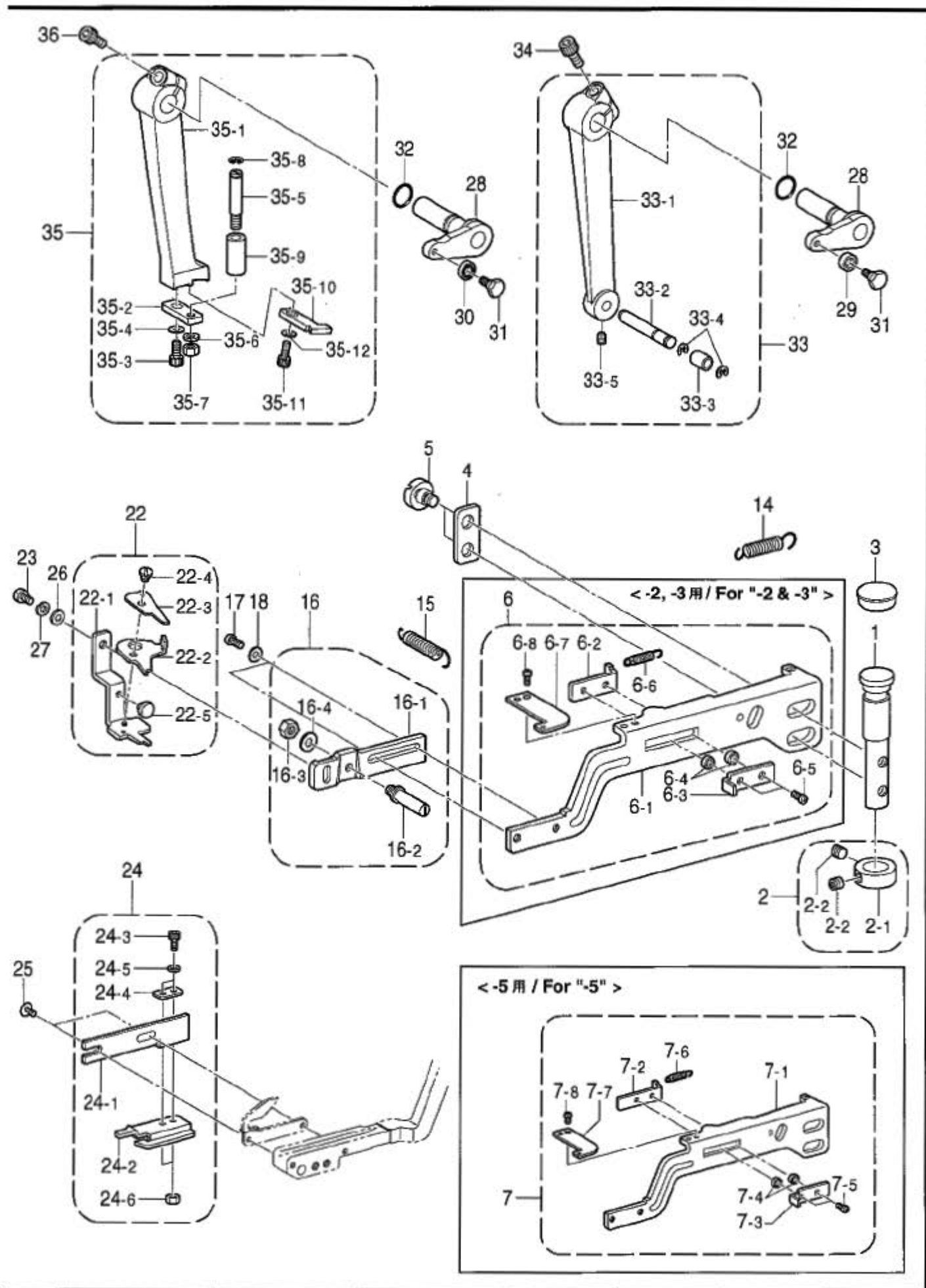

Q.上糸切り関係 / Upper thread trimmer mechanism

REF.NO	CODE	QTY	ヒンメイ	NAME OF PARTS	RM
1	S50394001	1	ウイトキリシデンシク	FULCRUM SHAFT, ;U-TR	
2	S21755001	1	セツカークミ	SET SCREW COLLAR ASSY	
2-1	110027001	1	セツカーク	SET SCREW COLLAR	
2-2	014760622	2	アトメネシ 5.95	SET SCREW, SOCKET SM5.95	
3	S23337001	1	ゴムセン18.5	RUBBER CAP, 18.5	
4	S52761001	1	ウイトキリレバ-サカネ	WASHER, RECTANGLE 15X32X2.4	
5	S19817001	2	ダンネシ 5.95	SHOULDER SCREW, SM5.95	
			<-2,-3用>	<For "-2 & -3">	
6	S51179101	1	ウイトキリレバ-ソウキミ	THREAD TRIMMER LEVER SET, U	
6-1	S50395001	1	ウイトキリレバ-クミ	U-THREAD TRIMMER LEVER ASSY	
6-2	S50398001	1	ハジミト-リトメタ	STOP PLATE	
6-3	S50399101	1	ハジミト-シタ	BACK PLATE	
6-4	S50400001	2	モト-シタカーク	COLLAR	
6-5	062670712	2	ナハ-コ357-40X7	SCREW, PAN SM3.57-40X7	
6-6	S50401001	1	ウイトキリモト-シハネ	SPRING	
6-7	S50402001	1	ハ-ネカキタ	SPRING HOOK PLATE	
6-8	062670512	1	ナハ-コ357-40X5	SCREW, PAN SM3.57-40X5	
			<-5用>	<For "-5">	
7	S54519001	1	ウイトキリレバ-ソウキミB	U-THREAD TRIMMER LEVER SET, B	
7-1	S50395001	1	ウイトキリレバ-クミ	U-THREAD TRIMMER LEVER ASSY	
7-2	S54520001	1	ハジミト-リトメタB	STOP PLATE, B	
7-3	S54521001	1	ハジミト-シタB	BACK PLATE, B	
7-4	S50400001	2	モト-シタカーク	COLLAR	
7-5	062670712	2	ナハ-コ357-40X7	SCREW, PAN SM3.57-40X7	
7-6	S50401001	1	ウイトキリモト-シハネ	SPRING	
7-7	S50402001	1	ハ-ネカキタ	SPRING HOOK PLATE	
7-8	062670512	1	ナハ-コ357-40X5	SCREW, PAN SM3.57-40X5	
14	S02563001	1	モト-シハネ	SPRING	
15	S02563001	1	モト-シハネ	SPRING	
16	S51180001	1	ハジミトリツケイタクミ	SETTING PLATE ASSY	
16-1	S50403001	1	ハジミトリツケイタ	SETTING PLATE	
16-2	159343001	1	ハジミサエシク	SUPPORT STUD	
16-3	021680202	1	ナツト2シユ4.37	NUT, 2 SM4.37	
16-4	025680132	1	ヒラサ-カネシユ4.37	WASHER, PLAIN S 4.37	
17	062680612	2	ナハ-コ4.37-40X6	SCREW, PAN SM4.37-40X6	
18	025680232	2	ヒラサ-カネシユ4.37	WASHER, PLAIN M 4.37	
22	S50404201	1	ハジミクミ	UPPER THREAD TRIMMER ASSY	
22-1	S50405101	1	ハジミDクミ	THREAD TRIMMER ASSY, D	
22-2	S50113101	1	ハジミM	UPPER THREAD TRIMMER, M	
22-3	141513001	1	ハジミU	UPPER THREAD TRIMMER, UPPER	
22-4	141514001	1	ハジミタ-ンネシ	SHOULDER SCREW, SM3.18	
22-5	S52431000	1	ハジミストツハ	U-THREAD TRIMMER STOPPER	
23	100644005	1	シメネシ 4.37	SCREW, SM4.37	
24	S58097001	1	ハジミヒラキカムクミ	OPENING CAM ASSY	
24-1	S50408001	1	ヒラキカムトリツケイタ	BRACKET, ;OPENING CAM	
24-2	S58098001	1	ハジミヒラキカム	OPENING CAM	
24-3	018300836	2	アホ-ル 3X8	BOLT, SOCKET M3X8	
24-4	S56251001	1	ヒラキカムサ-カネ	WASHER, PLAIN	
24-5	028030246	2	ハ-ネサ-カネ2-3	WASHER, SPRING 2-3	
24-6	021300206	2	2シユナツト3	NUT, 2 M3	
25	107093002	2	シメネシ 4.37	SCREW, SM4.37	
26	025680232	1	ヒラサ-カネシユ4.37	WASHER, PLAIN M 4.37	
27	028680242	1	ハ-ネサ-カネ2-4.37	WASHER, SPRING 2-4.37	
28	S50410001	2	イトキリク-ウレバ-	DRIVING LEVER, TR	
29	S50411001	1	ク-ウレバ-コ	ROLLER, ;D-LEVER	
30	S50412000	1	タマシ-クウケ	BALL BEARING	
31	S50413001	2	ク-ウレバ-タ-ンネシ	SHOULDER SCREW	
32	081012070	2	Oリング P12	O RING, P12	

Q . 上糸切り関係 / Upper thread trimmer mechanism

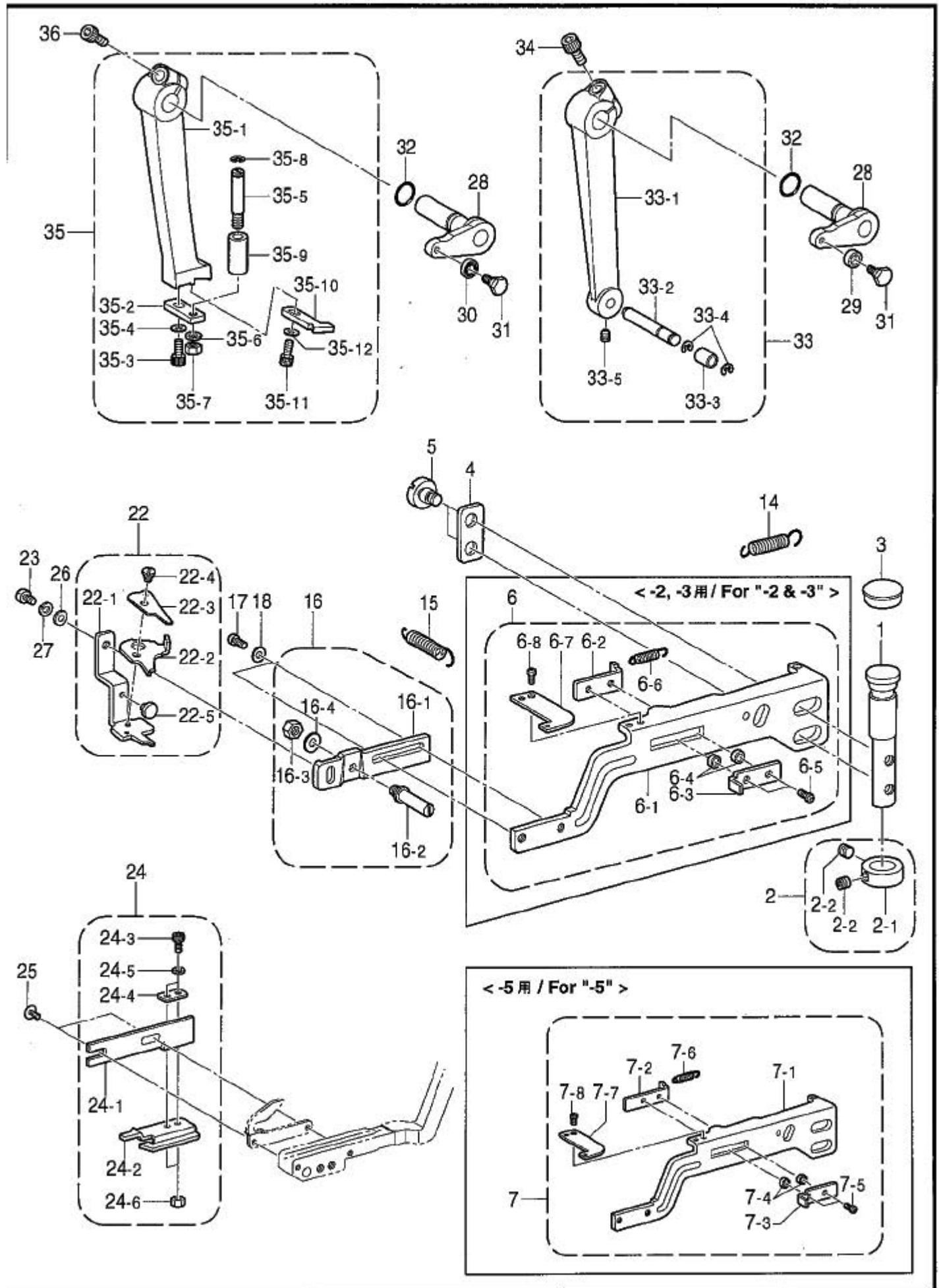

Q.上糸切り関係 / Upper thread trimmer mechanism

REF.NO	CODE	QTY	ヒンメイ	NAME OF PARTS	RM
33	S50419001	1	ゼンゴサトウテクミ	LONGITUDINAL FEED ARM ASSY	
33-1	S50414001	1	ゼンゴサトウテ	LONGITUDINAL FEED ARM	
33-2	S50415001	1	ゼンゴウテピン	PIN, ;L-FEED ARM	
33-3	S50416001	1	ゼンゴウテコロ	ROLLER, ;L-FEED ARM	
33-4	048040342	2	トメE4	RETAINING RING, E4	
33-5	014680622	1	アトメネシ4.37ホミ	SET SCREW, SOCKET (CP) SM4.37	
34	018061622	1	アホホト6X16	BOLT, SOCKET M6X16	
35	S51181001	1	イキリサトウテクミ	DRIVING ARM ASSY, TR	
35-1	S50417001	1	イキリサトウテ	DRIVING ARM, TR	
35-2	S50418001	1	ウテコロサイタ	SUPPORT PLATE	
35-3	018681022	1	アホホト4.37X10	BOLT, SOCKET SM4.37X10	
35-4	025680132	1	ヒラサカネシヨウ4.37	WASHER, PLAIN S 4.37	
35-5	S50420001	1	ウテコロシク	ROLLER SHAFT	
35-6	028050242	1	ハネサカネ2-5	WASHER, SPRING 2-5	
35-7	021500312	1	シユナツト5	NUT, 3 M5	
35-8	048060142	1	トメワシクヨウ C6	RETAINING RING, C6	
35-9	S50511001	1	サトウテコロ	ROLLER, ;D-ARM	
35-10	S50512001	1	ハサミトシストツハ	STOPPER	
35-11	018681022	1	アホホト4.37X10	BOLT, SOCKET SM4.37X10	
35-12	025680132	1	ヒラサカネシヨウ4.37	WASHER, PLAIN S 4.37	
36	018061622	1	アホホト6X16	BOLT, SOCKET M6X16	

R. 下糸切り関係 / Lower thread trimmer mechanism

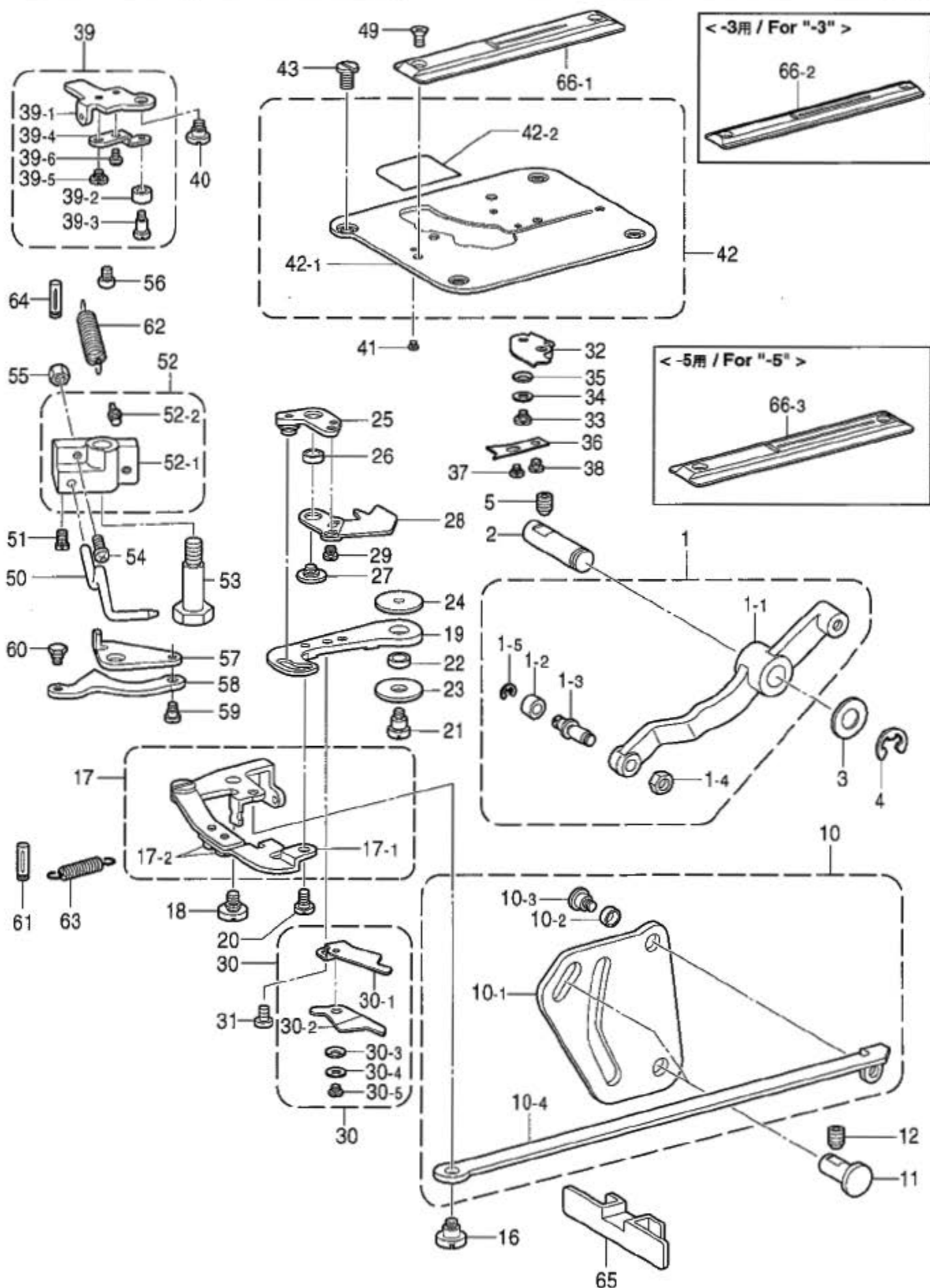

R.下糸切り関係 / Lower thread trimmer mechanism

REF.NO	CODE	Q'TY	ヒンメイ	NAME OF PARTS	RM
1	S51171001	1	シタイトリカムレバークミ	CAM LEVER ASSY, ;L-TR	
1-1	S50246001	1	シタイトリカムレバーク	CAM LEVER, ;L-TR	
1-2	107744001	1	コロ	ROLLER	
1-3	141519001	1	シタイトリカムシャフト	ROLLER SHAFT	
1-4	110161004	1	ナット4.76	NUT, SM4.76	
1-5	048030342	1	トメ7E3	RETAINING RING, E3	
2	159267001	1	シタイトリカムシャフト	CAM SHAFT, ;L-TR	
3	110494001	1	ワッシャー	WASHER, PLAIN 9.5	
4	048080342	1	トメ7E8	RETAINING RING, E8	
5	014760622	1	アタメネジ5.95	SET SCREW, SOCKET SM5.95	
10	S51170001	1	シタイトリカム	LOWER THREAD TRIMMER CAM ASSY	
10-1	S50247001	1	シタイトリカム	LOWER THREAD TRIMMER CAM	
10-2	S50411001	1	シタイトリカムコロ	ROLLER, ;D-LEVER	
10-3	145478101	1	ダンネジ4.76	SHOULDER SCREW, SOCKET SM4.76	
10-4	S50248001	1	シタイトリカムリンク	CONNECTIN ROD, ;L-TR	
11	150491101	2	シタイトリカムシャフト	LEVER SHAFT	
12	014760622	2	アタメネジ5.95	SET SCREW, SOCKET SM5.95	
16	159269001	1	シタイトリカムダンネジ	SHOULDER SCREW, SM4.37	
17	S50249001	1	シタイトリカムリンク	LINK ASSY, ;L-TR	
17-1	S59987001	1	シタイトリカムリンクA	CONNECTING ROD, A	
17-2	062680512	2	ナット4.37-40X5	SCREW, PAN SM4.37-40X5	
18	149127001	1	ダンネジ6.35	SHOULDER SCREW, SM6.35	
19	S50252001	1	メスサトウレバーク	KNIFE DRIVING LEVER	
20	113730001	1	ダンネジ4.37	SHOULDER SCREW, SM4.37	
21	159272001	1	メスサトウレバークダンネジ	SHOULDER SCREW	
22	S00903001	1	メスサトウレバークカラー	COLLAR	
23	S00901001	1	メスサトウレバークワッシャー	WASHER, PLAIN L 6.4 (U)	
24	S00902001	1	メスサトウレバークワッシャー	WASHER, PLAIN L 4.6 (D)	
25	S50253001	1	シタイトリカムレバーク	LEVER ASSY	
26	S50257001	1	シタイトリカムレバークカラー	COLLAR	
27	S00712101	1	シタイトリカムネジ	SCREW, SM4.37	
28	S50258001	1	シタイトリカムキ	LOWER THREAD RETAINER	
29	110215002	2	シタイトリカムネジ	SCREW SM3.57	
30	S50259101	1	シタイトリカムセット	FIXED KNIFE SET	
30-1	S50260101	1	シタイトリカム	FIXED KNIFE ASSY	
30-2	S50263001	1	シタイトリカム	MOVABLE KNIFE	
30-3	S50264000	1	ワッシャー4302	WASHER	
30-4	025040132	1	ワッシャーネジ	WASHER, PLAIN S 4	
30-5	060630312	1	ネジ238-56X3	SCREW, BIND SM2.38X3	
31	060670412	2	ネジ357-40X4	SCREW, BIND SM3.57-40X4	
32	S50265001	1	シタイトリカムプレート	LOWER THREAD CLAMP PLATE ASSY	
33	141514001	1	ダンネジ	SHOULDER SCREW, SM3.18	
34	025040132	1	ワッシャーネジ	WASHER, PLAIN S 4	
35	S50269000	1	ワッシャー5011	WASHER	
36	S50270000	1	シタイトリカムプレス	LOWER THREAD PRESSER	
37	145371001	1	ダンネジ2.38	SHOULDER SCREW, SM2.38	
38	110215002	1	シタイトリカムネジ	SCREW SM3.57	
39	S52432001	1	シタイトリカムプレート	OPENING PLATE ASSY	
39-1	S52433001	1	シタイトリカムプレートA	OPENING PLATE, A	
39-2	110167001	1	コロ	ROLLER	
39-3	110168001	1	シタイトリカムシャフト	ROLLER SHAFT	
39-4	S52434001	1	シタイトリカムプレートB	OPENING PLATE, B	
39-5	141514001	1	ダンネジ	SHOULDER SCREW, SM3.18	
39-6	123185001	1	ネジ3.57X4.5	SCREW 3.57X4.5	
40	149127001	1	ダンネジ6.35	SHOULDER SCREW, SM6.35	
41	105970001	1	シタイトリカムネジ	SCREW, SM2.38	
42	S52778001	1	ベースプレート	BASE PLATE ASSY	
42-1	S50303001	1	ベースプレート	BASE PLATE	
42-2	S52770000	1	シタイトリカムカバー	COVER, ;B-PLATE	
43	106629002	4	シタイトリカムネジ	SCREW, SM4.37	
49	S01696001	2	シタイトリカムネジ	SCREW, FLAT SM3.57X6	

R. 下糸切り関係 / Lower thread trimmer mechanism

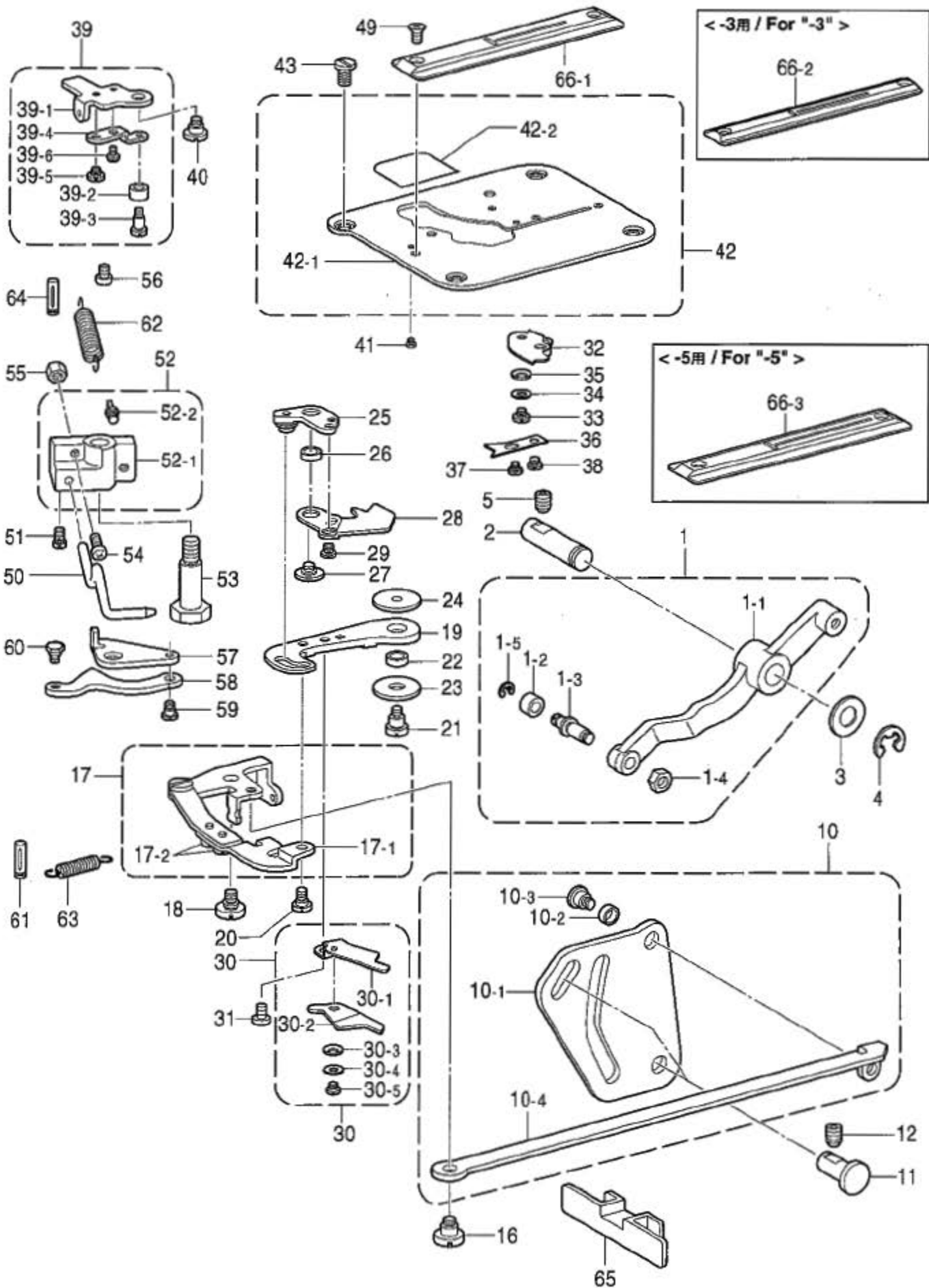

R.下糸切り関係 / Lower thread trimmer mechanism

REF.NO	CODE	QTY	ヒンメイ	NAME OF PARTS	RM
50	S50323000	1	ホビンオサエ	BOBBIN PRESSER	
51	S01998001	1	アタマツキトメジ3.57	SET SCREW, SM3.57-40X6	
52	S51172001	1	ホビンオサイタクミ	BOBBIN PRESSER BRACKET ASSY	
52-1	S50324001	1	ホビンオサイ	BOBBIN PRESSER BRACKET	
52-2	107639001	1	ハネカク	SPRING HOOK, U	
53	159924001	1	ストップレハダシ	SHOULDER SCREW	
54	062671612	1	ハコ357-40X16	SCREW, PAN SM3.57-40X16	
55	021670202	1	ナット2シ3.57	NUT, 2 SM3.57	
56	062680512	2	ハコ437-40X5	SCREW, PAN SM4.37-40X5	
57	S50325001	1	カヒラキヨイ	AUXILIARY PLATE	
58	S50326001	1	ホビンオサヒラキ	OPENING PLATE	
59	105237002	1	ダシ3.57	SHOULDER SCREW, SM3.57	
60	159113001	1	ダシ3.18	SHOULDER SCREW, SM3.18	
61	159379001	1	ピンツキンBX6X18	PIN, DOWEL BX6X18	
62	S50327001	2	ホビンオサヒラキハネ	SPRING, EXTENSION	
63	S50328001	1	タイトカミヒラキハネ	SPRING, PLATE	
64	159379001	1	ピンツキンBX6X18	PIN, DOWEL BX6X18	
65	S50329000	1	タイトキレンカハ	COVER	
66-1	S50664001	1	<-2用> ハイト1.4S	<For "-2"> NEEDLE PLATE, 1.4S	
66-2	S51248101	1	<-3用> ハイト1.2S-3	<For "-3"> NEEDLE PLATE, 1.2S-3	
66-3	S54522001	1	<-5用> ハイト1.4-50	<For "-5"> NEEDLE PLATE, 1.4-50	

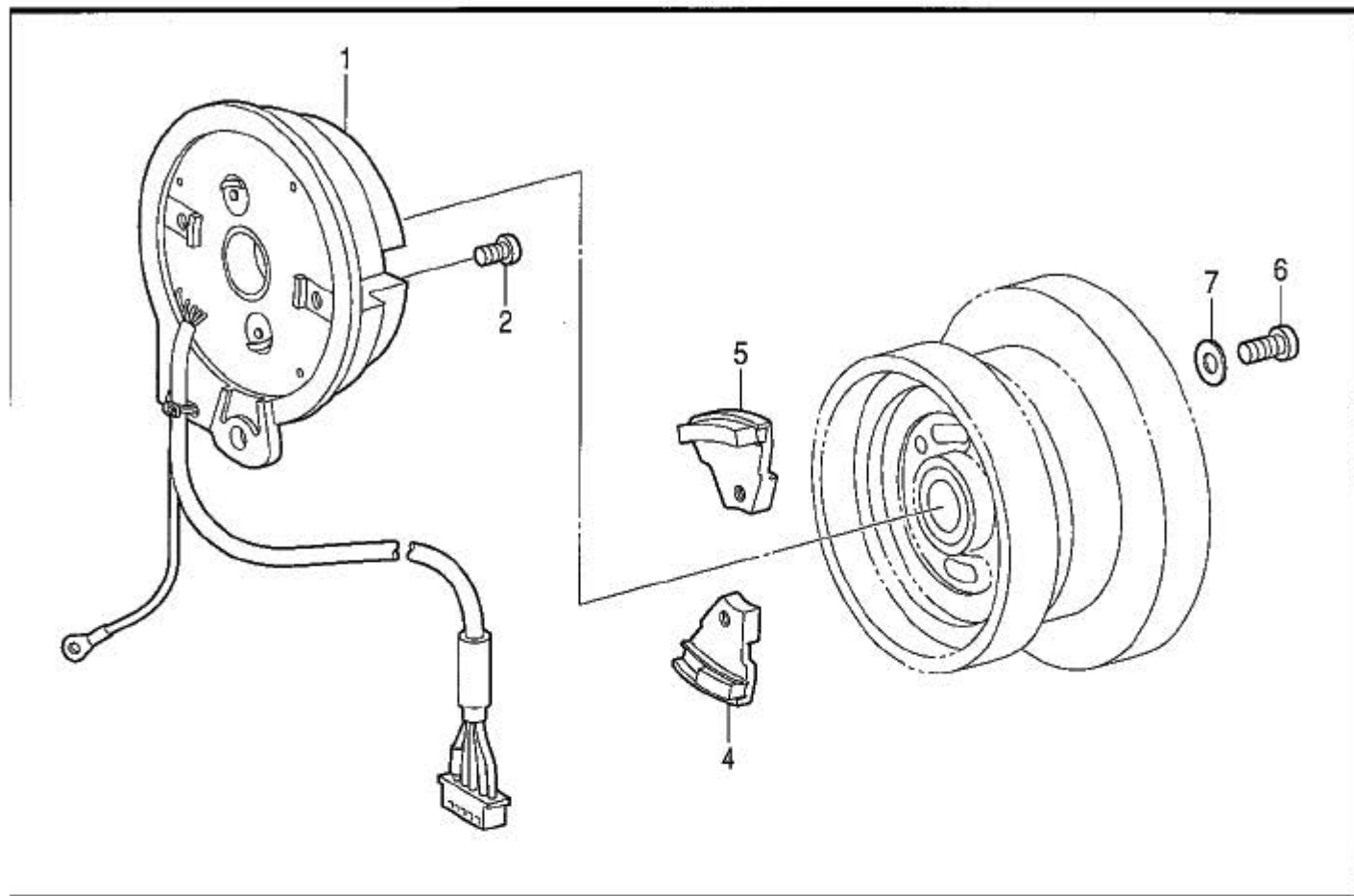

118-H80-501

T . 操作パネル関係 / Operation panel mechanism

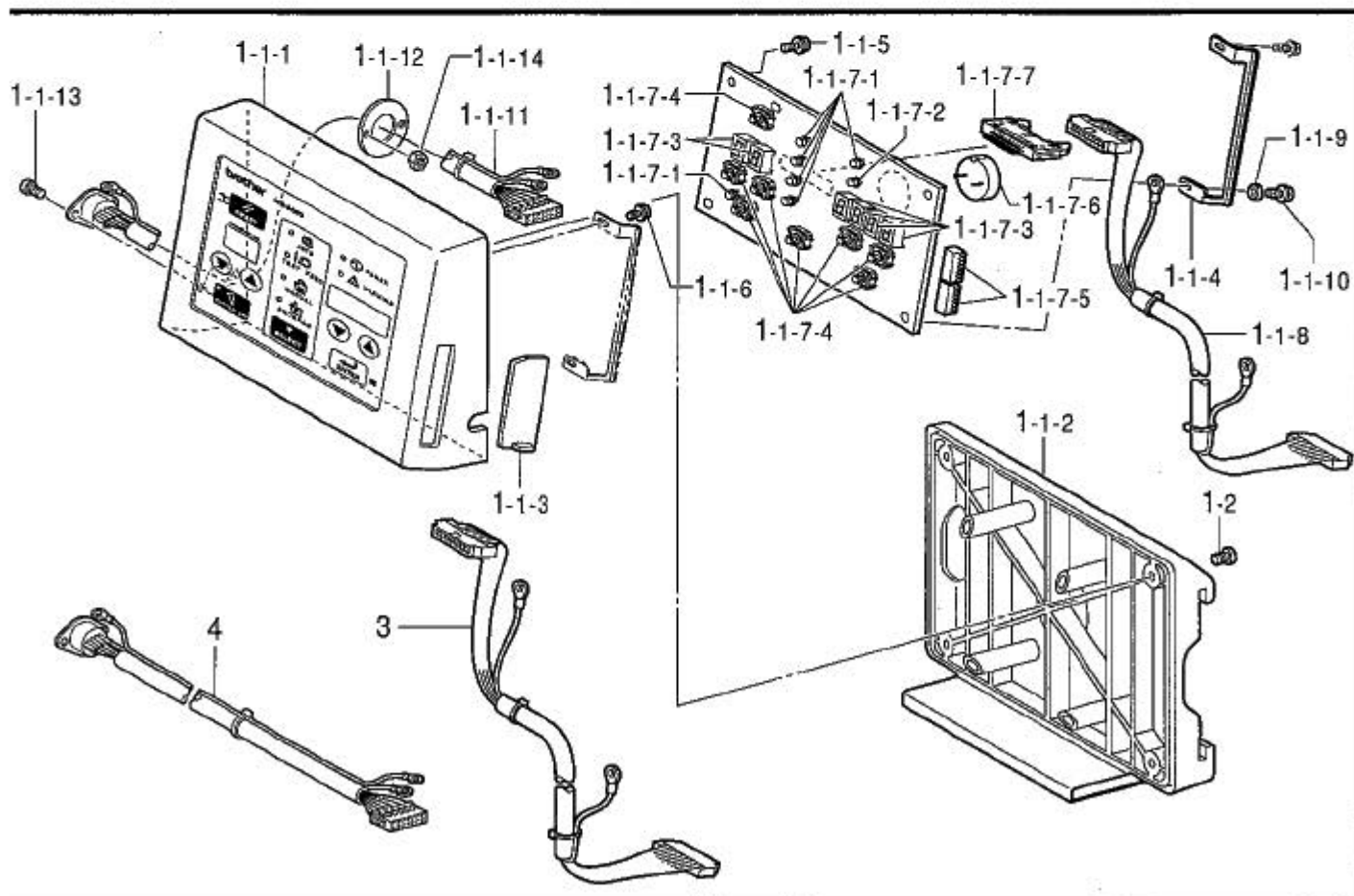

118-H80-530

S.針位置検出器関係 / Synchronizer

REF.NO	CODE	QTY	ヒンメイ	NAME OF PARTS	RM
1	S50657001	1	シンクロナイザ*クミH80	SYNCHRONIZER ASSY, H80	
2	062400806	2	ナ*コ4X8	SCREW, PAN M4X8	
4	S50354000	1	シ*シヤクミU	MAGNET ASSY, U	
5	S38082001	1	ハリウエシ*シヤクミ	MAGNET ASSY, U	
6	062681412	2	ナ*コ437-40X14	SCREW, PAN SM4.37-40X14	
7	025680132	2	ヒラサ*ガ*ネシヨウ4.37	WASHER, PLAIN S 4.37	

118-H80-501

T.操作パネル関係 / Operation panel mechanism

REF.NO	CODE	QTY	ヒンメイ	NAME OF PARTS	RM
1	S50656201	1	ソウサハ*ネルソウクミ	OPERATION PANEL SET	
1-1	S50451201	1	ソウサハ*ネルクミ	OPERATION PANEL ASSY	
1-1-1	S51901201	1	マIFレ-ムクミ	FRONT FRAME ASSY	
1-1-2	S49492000	1	ソウサハ*ネルウシロフレーム	REAR FRAME	
1-1-3	S49495000	1	ハ*ネルヨコカハ*	PANEL SIDE COVER	
1-1-4	S49496001	1	ハ*ネルヨコカハ*カ*イト*	COVR GUIDE, ;SIDE	
1-1-5	087310815	2	カフ*Bタイ3X8	TAPTITE, CUP B M3X8	
1-1-6	0A4400805	1	ナ*コサ*クミ4X8DA	SCREW, PAN (S/P WASHER) M4X8	
1-1-7	S50453000	1	ハ*ネルキハ*ンクミ	PANEL PCB ASSY	
1-1-7-1	S46703000	6	LEDPG5307S	LED, PG5307S	
1-1-7-2	S50455000	1	LEDBR5307S	LED, BR5307S	
1-1-7-3	S29023000	6	LEDGL9P040	LED, GL9P040	
1-1-7-4	S48579000	8	SWB3F-4050	SWITCH, B3F-4050	
1-1-7-5	U34870001	2	DIPSW KSP08	DIP SWITCH:KSP08	
1-1-7-6	S30280000	1	ブ*サ*-PKB24SPC36	BUZZER, PKB24SPC36	
1-1-7-7	S50456000	1	コネクタXG4A-2031	CONNECTOR, ;XG4A-2031	
1-1-8	S50457000	1	ハ*ネルケ-ブルクミ	PANEL CABLE ASSY	
1-1-9	XA2220050	2	キハ*ンオサエ	BOARD PRESSER	
1-1-10	087311015	2	カフ*Bタイ3X10	TAPTITE, CUP B M3X10	
1-1-11	S58974000	1	PRG/Mハ-ネスクミ	PRG/M HARNESS ASSY	
1-1-12	S58987001	1	ハ-ネストリツクイタ	HARNESS SETTING PLATE	
1-1-13	002301003	2	ナ*コネシ*3X10	SCREW, PAN M3X10	
1-1-14	021300206	1	2シユナツト3	NUT, 2 M3	
1-2	062300806	4	ナ*コ3X8	SCREW, PAN M3X8	
3	S53181000	1	ハ*ネルケ-ブルクミ	PANEL CABLE ASSY, L	
4	S58984000	1	PRG/Mハ-ネスクミ	PRG/M HARNESS ASSY, L	

118-H80-530

U1. コントロールボックス関係 / Control box mechanism

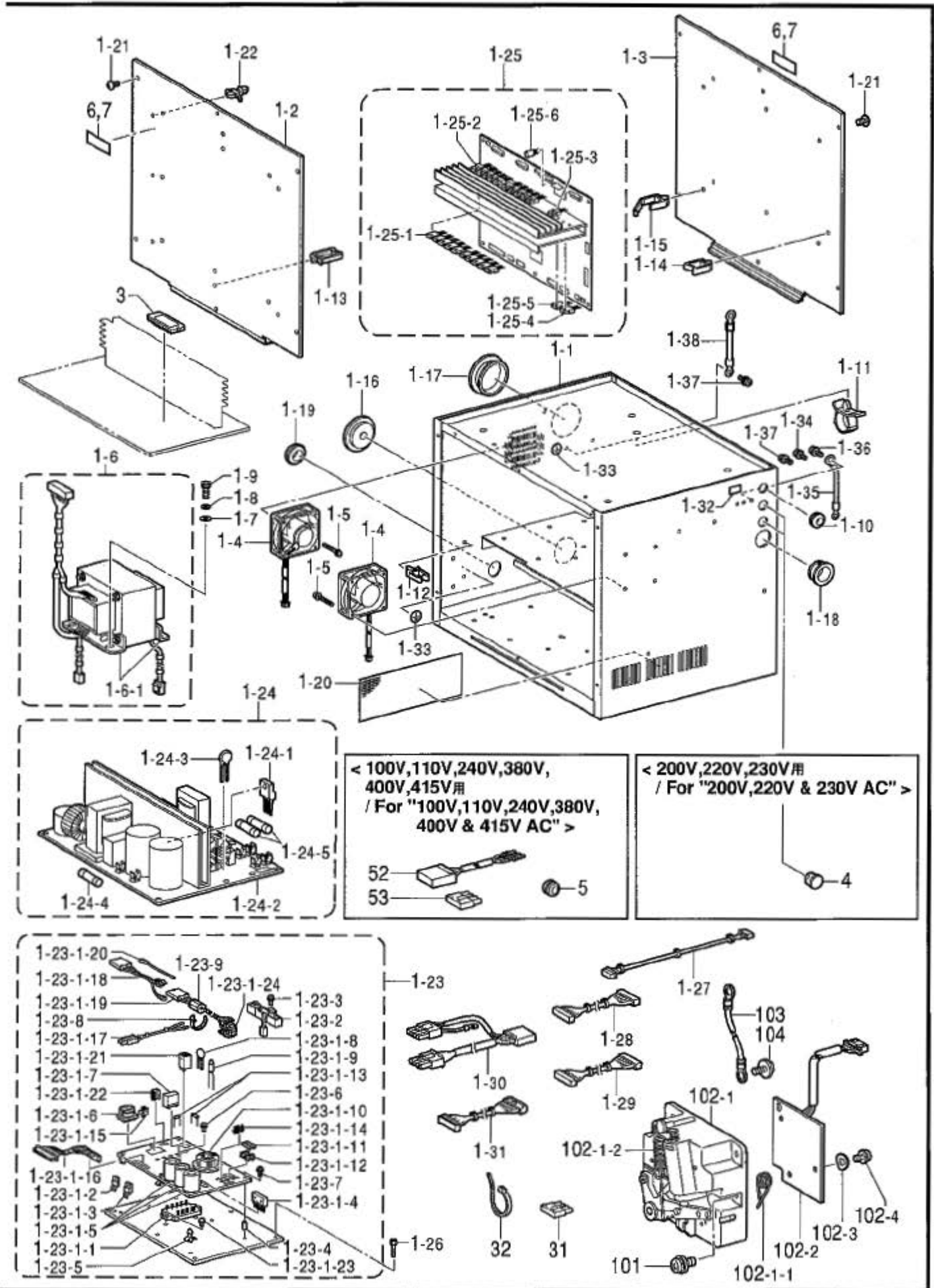

U1.コントロールボックス関係 / Control box mechanism

REF.NO	CODE	QTY	ヒンメイ	NAME OF PARTS	RM
1	S50421001	1	ホ`ツクミ	BOX ASSY	
1-1	S50566001	1	デンケ`ンホ`ツクス	POWER SUPPLY BOX	
1-2	S50567001	1	メインキハ`ントリツケイタ	SETTING PLATE, ;M-PCB	
1-3	S50568001	1	サフ`キハ`ントリツケイタ	SETTING PLATE, ;AUX-PCB	
1-4	S50660000	2	DCファンモ`タクミ	FAN MOTOR ASSY, DC	
1-5	0A5403005	6	ナハ`キ`クミ4X30DB	SCREW, PAN (S/P WASHER) M4X30	
1-6	S47723201	1	トランスクミ	TRANSFORMER ASSY	
1-6-1	S47749101	2	EZトランスフ`レート	SETTING PLATE, ;TRANSFORMER	
1-7	025050236	4	ヒラサ`カ`ネチユク5	WASHER, PLAIN M 5	
1-8	028050246	4	ハ`ネサ`カ`ネ2-5	WASHER, SPRING 2-5	
1-9	018501236	4	アサ`ネ`ネ5X12	BOLT, SOCKET M5X12	
1-10	S43186000	1	ブ`ツシBU687B	BUSH, BU687B	
1-11	S09142000	2	コト`クランプ`20L	CORD CLAMP, 20-L	
1-12	S43275000	14	コト`クランプ`WS2NS	CORD CLAMP, WS2NS	
1-13	S43276000	1	コト`クランプ`WS3NS	CORD CLAMP, WS3NS	
1-14	S50422000	3	コト`クランプ`WS2WS	CORD CLAMP, W2SWS	
1-15	S43318000	10	クランプ`LW8S2. 5W	CLAMP, LWS8S 2.5W	
1-16	S51118001	1	コト`ブ`ツシ	CORD BUSH	
1-17	S38820000	1	ブ`ツシ35	BUSHING, 35	
1-18	S50423000	1	ブ`ツシTB-1926	BUSHING, TB-1926	
1-19	S42227009	1	ク`ロメツMG-3	RUBBER CAP, MG-3	
1-20	S50424000	1	ホ`ウシ`ンアミ	FRAGMENT PROTECTOR NET	
1-21	008400604	12	ナ`ラス34X6	SCREW, TRUSS M4X6	
1-22	S00554000	23	サ`ネ`ト6NS	SUPPORT, 6NS	
1-23	S47721001	1	デンケ`ンEZキハ`ンクミ	POWER SUPPLY PCB ACCY, EZ	
1-23-1-1	J02443001	1	IPMPN20CSJ060	I-POWER MODULE, ;PM20CSJ060	
1-23-1-2	J03284001	1	FETFS5UM-18A	TRANSISTOR, FET :FS5UM-18R	
1-23-1-3	J03285001	1	FETFS3KM-18A	TRANSISTOR, FET :FS3KM-18A	
1-23-1-4	S47720000	1	SID20L6P45クミ	DIODE ASSY, BR :20L6P45	
1-23-1-5	J03324001	3	デン`C450B471	CAPACITOR, ALUM-ELEV :450B471	
1-23-1-6	S47735000	1	トランス28AG1L9AD	TRANSFORMER, 28AG1L9AD	
1-23-1-7	J02441001	1	リレ-G2R-1A6V	RELAY, G2R-1A6V	
1-23-1-8	S38201000	4	ハ`リスV14D471	VARISTOR :V14D471	
1-23-1-9	J03283001	1	S7フ`ソハ` DSA362M	SURGE ABSORBER, :DSA362M	
1-23-1-10	S47733000	1	コイルNF10TP102	COIL, :NF10TP102	
1-23-1-11	218469001	2	カヒユ`ス` 15A#2	FUSE	
1-23-1-12	J01684001	4	ヒユ`ス`ホルダ` F062	FUSE HOLDER, F062	
1-23-1-13	J02727001	2	カヒユ`ス` 2A250V	GLASS FUSE, 2A/250V	
1-23-1-14	S47734000	3	コネク`タB4P5-VB-2	CONNECTOR, B4P5-VB-2	
1-23-1-15	J02449001	1	コネク`タ5281-02A	CONNECTOR, 5281-02A	
1-23-1-16	S47730000	1	IPMコ`ト`P	IPM CORD, P	
1-23-1-17	S47728000	1	DC300Vハ`ネSP	HARNESS, P DC 300V	
1-23-1-18	S47727000	1	モ`タハ`ネSP	MOTOR HARNESS, P	
1-23-1-19	S47725000	1	デンケ`ンハ`ネSP	POWER SUPPLY HARNESS, P	
1-23-1-20	S47726000	1	デンケ`ンア`スセンP	GROUND WIRE, P	
1-23-1-21	J03296001	1	フィンPR1616-25-PB	HEATSINK, ;PR1616-25-PB	
1-23-1-22	S47729000	1	フィンOSH-1025-MP	HEATSINK, ;OSH-1025-MP	
1-23-1-23	221419001	2	ナハ`セツ3X10DB	SCREW	
1-23-1-24	J03291001	1	コアESD-R-25B	CORE, ESD-R-25B	

118-H80-502

RM欄に*が付いている部品をご注文頂きますと、基板等必要な部品が一式入ったセットになっております。
When ordering parts which have an asterisk(*) in the RM column, these parts will be supplied as a set together with other necessary parts such as circuit boards.

U1.コントロールボックス関係 / Control box mechanism

REF.NO	CODE	Q'TY	品名	NAME OF PARTS	RM
1-23-3	S47694000	1	MR-A40101Jクミ	F-RESISTOR ASSY, MR-A40J101	
1-23-4	0A5400805	1	ナハサクミ4X8DB	SCREW, PAN (S/P WASHER) M4X8	
1-23-5	S47693000	2	スハサ4EP-12	SPACER, 4EP-12	
1-23-6	S47724000	5	スハサ7NS	SPACER, 7NS	
1-23-7	229017001	4	ナハセット4X10DA	SCREW, PAN (S/P WASHER) M4X10	
1-23-8	J02343001	2	ナハサクミ4X16DB	SCREW, PAN (S/P WASHER) M4X16	
1-23-9	S39819000	1	コートクランプ1259	CORD CLAMP, 1259	
1-23-10	S40621000	1	EMIコアESD-SR-15	EMI CORE, ESD-SR-15	
1-24	S50425001	1	テングンEHキハングミ	POWER SUPPLY PCB ASSY, EH	
1-24-1	S38200000	2	MOSFET2SK1938	TRANSISTOR, :2SK1938	
1-24-2	232384001	1	S77ソハ DSA362MA	SURGE ABSORBER :DSA362MA	
1-24-3	S38201000	2	バリスタV14D471	VARIATOR :V14D471	
1-24-4	S08030000	1	ヒューズ5AFB	FUSE, 5A :FB	
1-24-5	153242000	2	ヒューズ6A	FUSE, 6A	
1-25	S50431001	1	サブキハングミ	SUB PCB ASSY	
1-25-1	S38155000	5	MOSFET2SK1306	TRANSISTOR, FET :2SK1306	
1-25-2	S50645000	1	MOSFET2SK1307	TRANSISTOR, FET :2SK1307	
1-25-3	Y44715591	1	テングンC50B471	CAPACITOR, ALUM-ELEC :50B471	
1-26	018401236	5	アハトル4X12	BOLT, SOCKET M4X12	
1-27	S50437000	1	PERコート	CORD, PER	
1-28	S50438000	1	EX32ハネス	HARNESS, EX32	
1-29	S50439000	1	EX26ハネス	HARNESS, EX26	
1-30	S50440000	1	テングンACハネス	POWER SUPPLY HARNESS, AC	
1-31	S50441000	1	テングンDCハネス	POWER SUPPLY HARNESS, DC	
1-32	S37059001	1	PEマーク	LABEL, PE	
1-33	S37060001	2	アスマーク	LABEL, GROUNDING	
1-34	0A5401006	2	ナハコハネヒラ4X10	SCREW, PAN (S/P WASHER) M4X10	
1-35	S50484000	1	アースコート	GROUND WIRE	
1-36	0A5401006	1	ナハコハネヒラ4X10	SCREW, PAN (S/P WASHER) M4X10	
1-37	0A5401006	1	ナハコハネヒラ4X10	SCREW, PAN (S/P WASHER) M4X10	
1-38	S50644001	1	アースコート	GROUND WIRE	
3	S50488100	1	PROMB800Eクミ	BOX SET, A2H	
4	S20345001	2	<220V, 220V, 230V用> ゴムセン14	<For "200V,220V & 230V AC"> RUBBER CAP, 14	
5	S43186000	2	<100V, 110V, 240 380V, 400V, 415V用> ブッシュBU687B	<For "100V,110V & 240V, 380V,400V & 415V AC"> BUSH, BU687B	
6	S38352101	2	テングンキラハル.4カコク	LABEL, ELEC. SHOCK 4 LANG.	
7	S38353101	2	テングンキラハル.ワ	LABEL, ELEC. SHOCK JPN.	
8	S10820000	1	テングンアツラハル	LABEL, 100V AC	
9	S10820001	1	テングンアツラハル	LABEL, 200V AC	
10	S10820002	1	テングンアツラハル	LABEL, 110V AC	
11	S10820003	1	テングンアツラハル	LABEL, 220V AC	
12	S10820004	1	テングンアツラハル	LABEL, 230V AC	
13	S10820005	1	テングンアツラハル	LABEL, 240V AC	
14	S10820006	1	テングンアツラハル	LABEL, 380V AC	
15	S10820007	1	テングンアツラハル	LABEL, 415V AC	
16	S10820008	1	テングンアツラハル	LABEL, 400V AC	
31	S38146000	1	コネクタ3191-04R	CONNECTOR, 3191-04R	
32	228475000	1	ケツソクバンド1.9X80	FASTENING BAND, 1.9X80	

U1.コントロールボックス関係 / Control box mechanism

REF.NO	CODE	Q'TY	ヒンメイ	NAME OF PARTS	RM
52	S50483100	2	<100V, 110V, 240 380V, 400V, 415V用> B-OUTハンカハーネス	<For "100V, 110V & 240V, 380V, 400V & 415V AC"> CONVERSION HARNESS, B-OUT	
53	S38146000	2	コネクタ3191-04R	CONNECTOR, 3191-04R	
101	0A5501005	3	ナハサクM5X10DB	SCREW, PAN (S/P WASHER) M5X10	
102	J80814001	1	TREADLE UNIT EZ	TREADLE UNIT, EZ	
102-1	J03419001	1	フミコミハースクEZ-1	TREADLE BASE ASSY, EZ-EXPORT	
102-1-1	J01935001	1	ツイストリハネ28.8X30	SPRING, TWIST 28.8X30	
102-1-2	J00649001	1	ヒキハネ12.6X86	SPRING, EXTENSION 12.6X86	
102-2	J80813001	1	PS CIRCUIT EZ	PS PCB, EZ	
102-3	J02130001	3	ワッシャー03X4.3X8	WASHER, WAVE 03X4.3X8	
102-4	037401015	3	Vナハタツピン4X10	TAPPING SCREW, PAN V M4X10	
103	J03417001	1	アースコート	GROUND WIRE ASSY	
104	229017001	1	ナハセツト4X10DA	SCREW, PAN (S/P WASHER) M4X10	
			" 補給用部品 "	"For Supply parts"	
			<三相200V国内用>	<For Japan only>	
H-1	S50501201	1	ボックスセットA1V		*
			<三相220V輸出用>	<For "3-Phase 220V AC">	
H-2	S50502201	1	ボックスセットA2V	BOX SET, A2V	*
			<単相220V輸出用>	<For "1-Phase 220V AC">	
H-3	S50503201	1	ボックスセットA3V	BOX SET, A3V	*
			<単相100V国内用>	<For Japan only>	
H-4	S50504301	1	ボックスセットB1V		*
			<単相110V輸出用>	<For "1-Phase 110V AC">	
H-5	S50505301	1	ボックスセットB2V	BOX SET, B2V	*
			<三相415V輸出用>	<For "3-Phase 415V AC">	
H-6	S50506301	1	ボックスセットC1V	BOX SET, C1V	*
			<三相380V輸出用>	<For "3-Phase 380V AC">	
H-7	S50507301	1	ボックスセットC2V	BOX SET, C2V	*
			<単相240V輸出用>	<For "1-Phase 240V AC">	
H-8	S50508301	1	ボックスセットC3V	BOX SET, C3V	*
			<三相400V輸出用>	<For "3-Phase 400V AC">	
H-9	S50509301	1	ボックスセットEV	BOX SET, EV	*
			<単相230V輸出用>	<For "1-Phase 230V AC">	
H-10	S50510201	1	ボックスセットFV	BOX SET, FV	*

118-H80-502

RM欄に*が付いている部品をご注文頂きますと、基板等必要な部品が一式入ったセットになっております。
When ordering parts which have an asterisk(*) in the RM column, these parts will be supplied as a set together with other necessary parts such as circuit boards.

< 三相200V,220V用 / For "3-Phase 200V & 220V AC" >

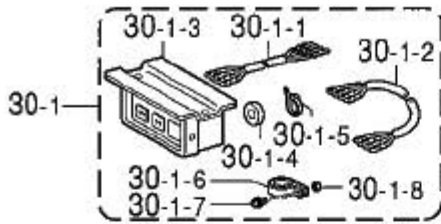

< 単相220V用 / For "1-Phase 220V AC" >

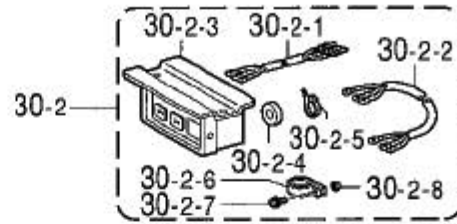

< 単相100V用 / For Japan only >

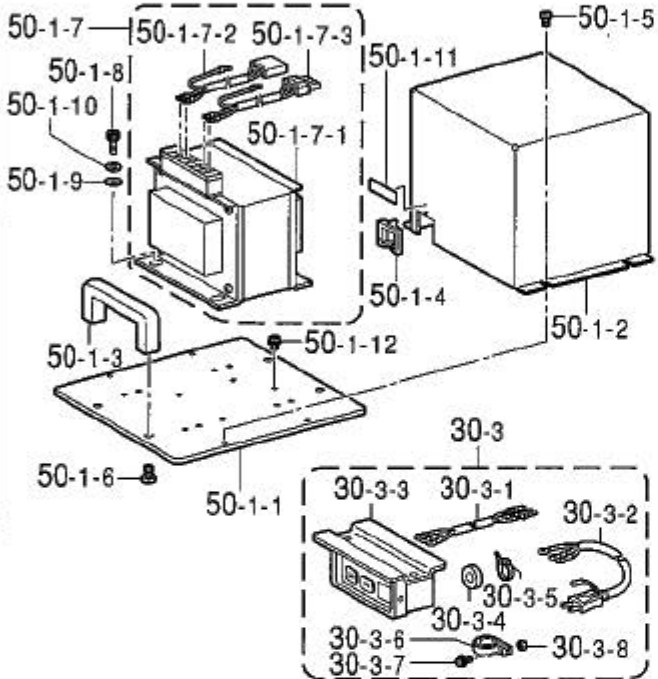

< 単相110V用 / For "1-Phase 110V AC" >

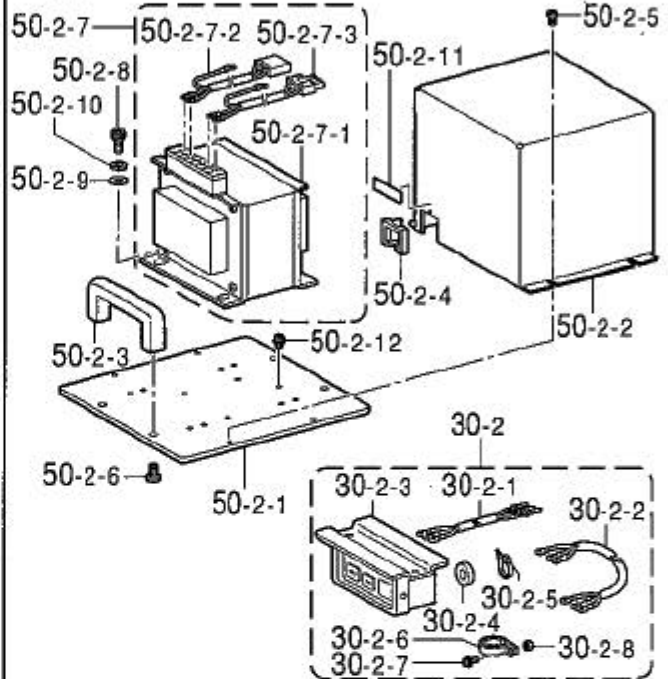

< 単相240V / For "1-Phase 240V AC" >

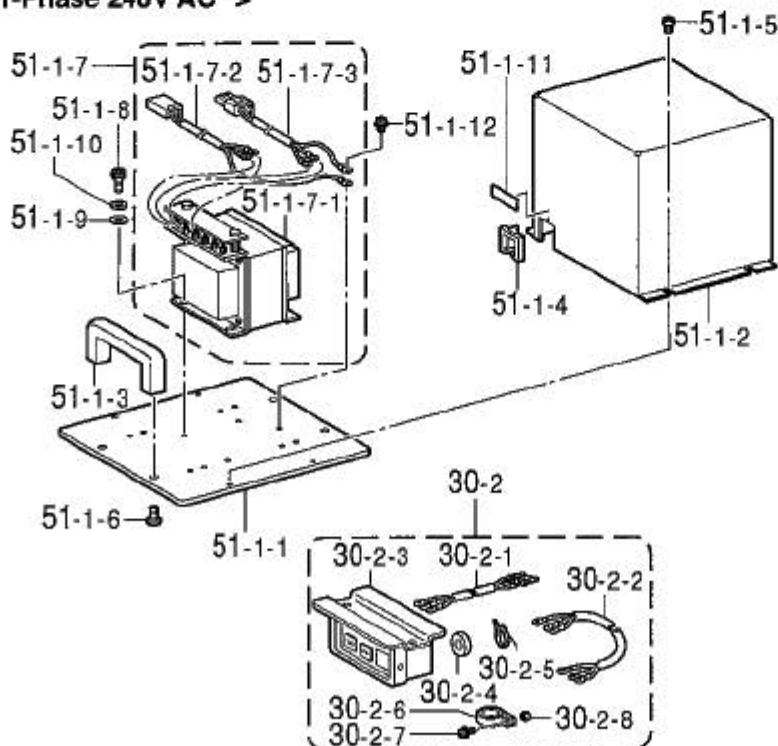

U2.コントロールボックス関係 / Control box mechanism

REF.NO	CODE	Q'TY	ヒンメイ	NAME OF PARTS	RM
			<三相200V, 220V用>	<For "3-Phase 200V & 220V AC">	
30-1	S50442001	1	デンゲンSWカミA	POWER SUPPLY SWITCH ASSY, A	
30-1-1	S50443000	1	デンゲンコードA1	POWER SUPPLY CORD, A1	
30-1-2	S38133000	1	デンゲンコード	POWER SUPPLY HARNESS	
30-1-3	J02657001	1	3P押しSW#17	PUSH SWITCH, 3P #17	
30-1-4	224514001	2	セツインタ	INSULATION PLATE	
30-1-5	218859001	3	バインダM150	BINDER, M150	
30-1-6	S40623000	1	EMIコアTR-40-27	EMI CORE, TR-40-27	
30-1-7	0A4401205	1	ナハサクミ4X12A	SCREW, PAN (S/P WASHER) M4X12	
30-1-8	021040105	1	ナツト1シユ	NUT, M4	
			<単相110V, 220V, 240V用>	<For "1-Phase 110V, 220V & 240V AC">	
30-2	S50444001	1	デンゲンSWカミB	POWER SUPPLY SWITCH ASSY, B	
30-2-1	S50445000	1	デンゲンコードB	POWER SUPPLY CORD, B	
30-2-2	S47595000	1	デンゲンコード用シユツ	POWER SUPPLY HARNESS, EXP.	
30-2-3	J02657001	1	3P押しSW#17	PUSH SWITCH, 3P #17	
30-2-4	224514001	2	セツインタ	INSULATION PLATE	
30-2-5	218859001	3	バインダM150	BINDER, M150	
30-2-6	S40623000	1	EMIコアTR-40-27	EMI CORE, TR-40-27	
30-2-7	0A4401205	1	ナハサクミ4X12A	SCREW, PAN (S/P WASHER) M4X12	
30-2-8	021040105	1	ナツト1シユ	NUT, M4	
			<単相100V用>	<For Japan only>	
30-3	S50446001	1	デンゲンSWカミC	_____	
30-3-1	S50445000	1	デンゲンコードB	_____	
30-3-2	S38118000	1	デンゲンコードコナイ	_____	
30-3-3	J02657001	1	3P押しSW#17	_____	
30-3-4	224514001	2	セツインタ	_____	
30-3-5	218859001	3	バインダM150	_____	
30-3-6	S40623000	1	EMIコアTR-40-27	_____	
30-3-7	0A4401205	1	ナハサクミ4X12A	_____	
30-3-8	021040105	1	ナツト1シユ	_____	
			<単相100V用>	<For Japan only>	
50-1	S50632101	1	ハンカトランスB100クミ	_____	
50-1-1	S54027001	1	トランスベース	_____	
50-1-2	S54028001	1	トランスフタ	_____	
50-1-3	S50474000	2	トツテ	_____	
50-1-4	S41964000	1	ブツシユ	_____	
50-1-5	062500602	4	ナハコ5X6	_____	
50-1-6	S23618001	4	シメネジ6X10	_____	
50-1-7	S50633100	1	ハンカトランスB100	_____	
50-1-7-1	S50649000	1	ハンカトランスB	_____	
50-1-7-2	S50485100	1	TR-INハーネ	_____	
50-1-7-3	S50486100	1	TR-OUTハーネ	_____	
50-1-8	018060831	4	アホネト6X8	_____	
50-1-9	025060236	4	ヒラサカネコ6	_____	
50-1-10	028060246	4	ハネサカネコ6	_____	
50-1-11	S10820000	1	デンアラハル	_____	
50-1-12	0A4400606	1	ナハサクミ4X6DA	_____	
			<単相110V用>	<For "1-Phase 110V AC">	
50-2	S50634101	1	ハンカトランスB110クミ	TRANSFORMER ASSY, B110 ;CONV.	
50-2-1	S54027001	1	トランスベース	BASE PLATE, TRANS.	
50-2-2	S54028001	1	トランスフタ	COVER, TRANS.	
50-2-3	S50474000	2	トツテ	HANDLE	
50-2-4	S41964000	1	ブツシユ	BUSH	
50-2-5	062500602	4	ナハコ5X6	SCREW, PAN M5X6	
50-2-6	S23618001	4	シメネジ6X10	SCREW, M6X10	
50-2-7	S50635100	1	ハンカトランスB110	TRANSFORMER, B100 ;CONV.	
50-2-7-1	S50649000	1	ハンカトランスB	CONVERSION TRANSFORMER, B	

< 三相200V,220V用 / For "3-Phase 200V & 220V AC" >

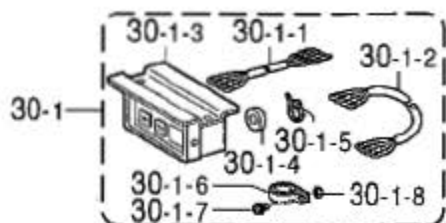

< 単相220V用 / For "1-Phase 220V AC" >

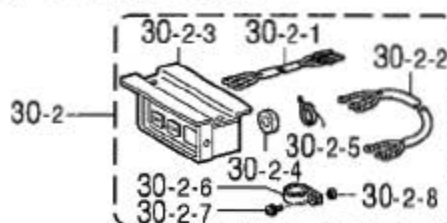

< 単相100V用 / For Japan only >

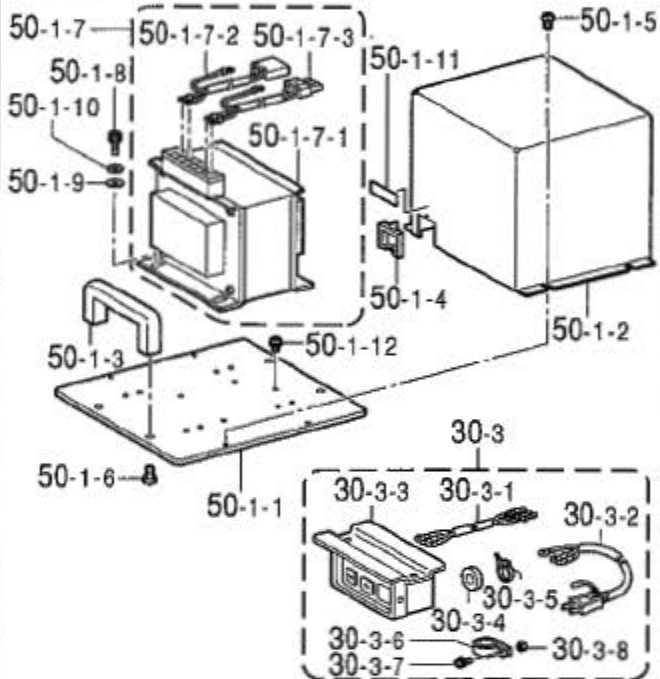

< 単相110V用 / For "1-Phase 110V AC" >

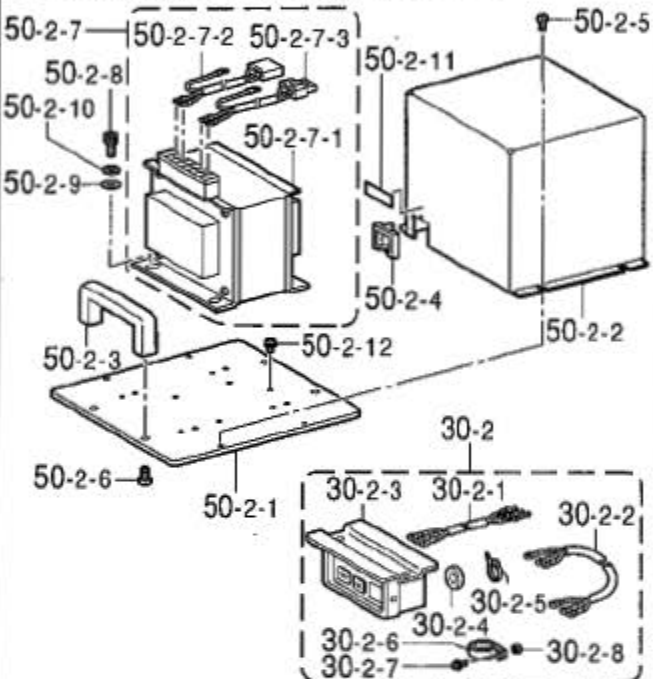

< 単相240V / For "1-Phase 240V AC" >

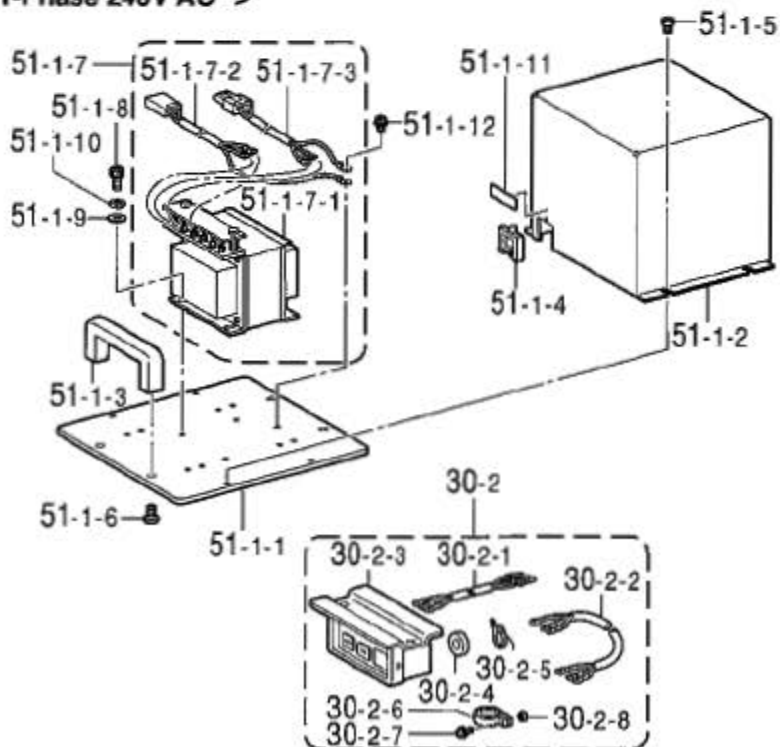

U2.コントロールボックス関係 / Control box mechanism

REF.NO	CODE	QTY	ヒンメイ	NAME OF PARTS	RM
			<単相110V用>	<For "1-Phase 110V AC">	
50-2-7-2	S50485100	1	TR-INハーネス	HARNESS, TR-IN	
50-2-7-3	S50486100	1	TR-OUTハーネス	HARNESS, TR-OUT	
50-2-8	018060831	4	ボルトM6X8	BOLT, SOCKET M6X8	
50-2-9	025060236	4	ワッシャーM6	WASHER, PLAIN M 6	
50-2-10	028060246	4	ワッシャーM6	WASHER, SPRING 2-6	
50-2-11	S10820002	1	テンプレート	LABEL, 110V AC	
50-2-12	0A4400606	1	ネジM4X6DA	SCREW, PAN (S/P WASHER) M4X6	
			<単相240V用>	<For "1-Phase 240V AC">	
51-1	S50636101	1	変圧器C240	TRANSFORMER ASSY, C240 ;CONV.	
51-1-1	S54027001	1	ベースプレート	BASE PLATE, TRANS.	
51-1-2	S54028001	1	カバー	COVER, TRANS.	
51-1-3	S50474000	2	ハンドル	HANDLE	
51-1-4	S41964000	1	ブッシュ	BUSH	
51-1-5	062500602	4	ネジM5X6	SCREW, PAN M5X6	
51-1-6	S23618001	4	ネジM6X10	SCREW, M6X10	
51-1-7	S50637100	1	変圧器C240	TRANSFORMER, C240 ;CONV.	
51-1-7-1	S38128000	1	変圧器	CONVERSION TRANSFORMER, C	
51-1-7-2	S50485100	1	TR-INハーネス	HARNESS, TR-IN	
51-1-7-3	S50486100	1	TR-OUTハーネス	HARNESS, TR-OUT	
51-1-8	018060831	4	ボルトM6X8	BOLT, SOCKET M6X8	
51-1-9	025060236	4	ワッシャーM6	WASHER, PLAIN M 6	
51-1-10	028060246	4	ワッシャーM6	WASHER, SPRING 2-6	
51-1-11	S10820005	1	テンプレート	LABEL, 240V AC	
51-1-12	0A4400606	1	ネジM4X6DA	SCREW, PAN (S/P WASHER) M4X6	

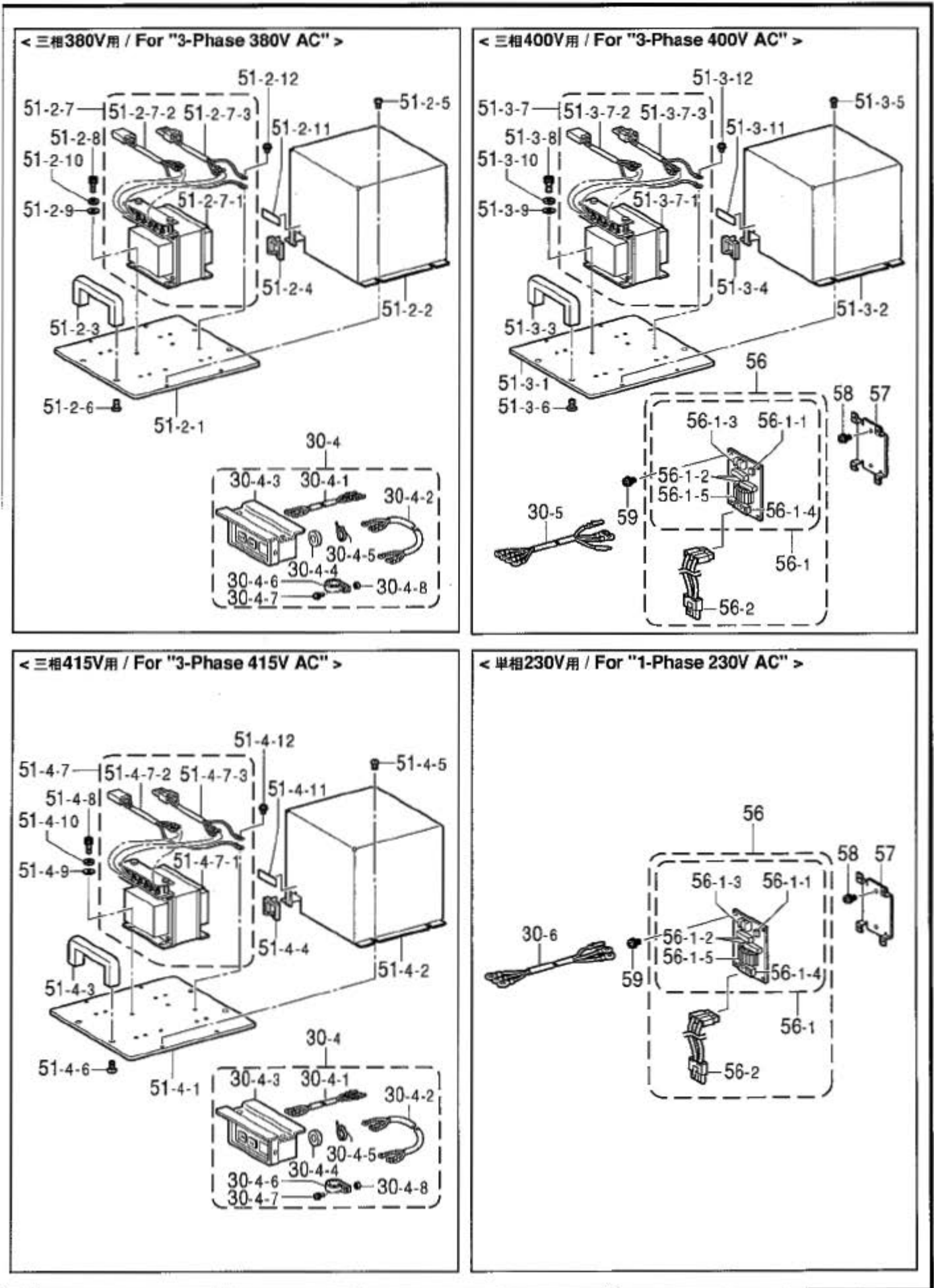

U3.コントロールボックス関係 / Control box mechanism

REF.NO	CODE	Q'TY	ヒンメイ	NAME OF PARTS	RM
			<三相380V、415V用>	<For "3-Phase 380V & 415V AC">	
30-4	S50447001	1	デンゲンSWキD	POWER SUPPLY SWITCH ASSY, D	
30-4-1	S50445000	1	デンゲンコードB	POWER SUPPLY CORD, B	
30-4-2	S38133000	1	デンゲンコード	POWER SUPPLY HARNESS	
30-4-3	J02657001	1	3P押しSW#17	PUSH SWITCH, 3P #17	
30-4-4	224514001	2	セツインタ	INSULATION PLATE	
30-4-5	218859001	3	バインダM150	BINDER, M150	
30-4-6	S40623000	1	EMICORTR-40-27	EMI CORE, TR-40-27	
			<三相400V用>	<For "3-Phase 400V AC">	
30-5	S50448000	1	デンゲンコードE	POWER SUPPLY CORD, E	
			<単相230V用>	<For "1-Phase 230V AC">	
30-6	S50500000	1	デンゲンコードF	AC CORD, F	
			<三相380V用>	<For "3-Phase 380V AC">	
51-2	S50638101	1	ハンカトランスC380クミ	TRANSFORMER ASSY, C380 ;CONV.	
51-2-1	S54027001	1	トランスベースタ	BASE PLATE, TRANS.	
51-2-2	S54028001	1	トランスタ	COVER, TRANS.	
51-2-3	S50474000	2	ツテ	HANDLE	
51-2-4	S41964000	1	ブッシュ	BUSH	
51-2-5	062500602	4	ナットM5X6	SCREW, PAN M5X6	
51-2-6	S23618001	4	シメネジM6X10	SCREW, M6X10	
51-2-7	S50639100	1	ハンカトランスC380	TRANSFORMER, C380 ;CONV.	
51-2-7-1	S38128000	1	ハンカトランスC	CONVERSION TRANSFORMER, C	
51-2-7-2	S50485100	1	TR-INハーネス	HARNESS, TR-IN	
51-2-7-3	S50486100	1	TR-OUTハーネス	HARNESS, TR-OUT	
51-2-8	018060831	4	ボルトM6X8	BOLT, SOCKET M6X8	
51-2-9	025060236	4	ワッシャーM6	WASHER, PLAIN M 6	
51-2-10	028060246	4	ワッシャーM6	WASHER, SPRING 2-6	
51-2-11	S10820006	1	デンアラベル	LABEL, 380V AC	
51-2-12	0A4400606	1	ナットM4X6DA	SCREW, PAN (S/P WASHER) M4X6	
			<三相400V用>	<For "3-Phase 400V AC">	
51-3	S50640101	1	ハンカトランスC400クミ	TRANSFORMER ASSY, C400 ;CONV.	
51-3-1	S54027001	1	トランスベースタ	BASE PLATE, TRANS.	
51-3-2	S54028001	1	トランスタ	COVER, TRANS.	
51-3-3	S50474000	2	ツテ	HANDLE	
51-3-4	S41964000	1	ブッシュ	BUSH	
51-3-5	062500602	4	ナットM5X6	SCREW, PAN M5X6	
51-3-6	S23618001	4	シメネジM6X10	SCREW, M6X10	
51-3-7	S50641100	1	ハンカトランスC400	TRANSFORMER, C400 ;CONV.	
51-3-7-1	S38128000	1	ハンカトランスC	CONVERSION TRANSFORMER, C	
51-3-7-2	S50485100	1	TR-INハーネス	HARNESS, TR-IN	
51-3-7-3	S50486100	1	TR-OUTハーネス	HARNESS, TR-OUT	
51-3-8	018060831	4	ボルトM6X8	BOLT, SOCKET M6X8	
51-3-9	025060236	4	ワッシャーM6	WASHER, PLAIN M 6	
51-3-10	028060246	4	ワッシャーM6	WASHER, SPRING 2-6	
51-3-11	S10820008	1	デンアラベル	LABEL, 400V AC	
51-3-12	0A4400606	1	ナットM4X6DA	SCREW, PAN (S/P WASHER) M4X6	

< 三相380V用 / For "3-Phase 380V AC" >

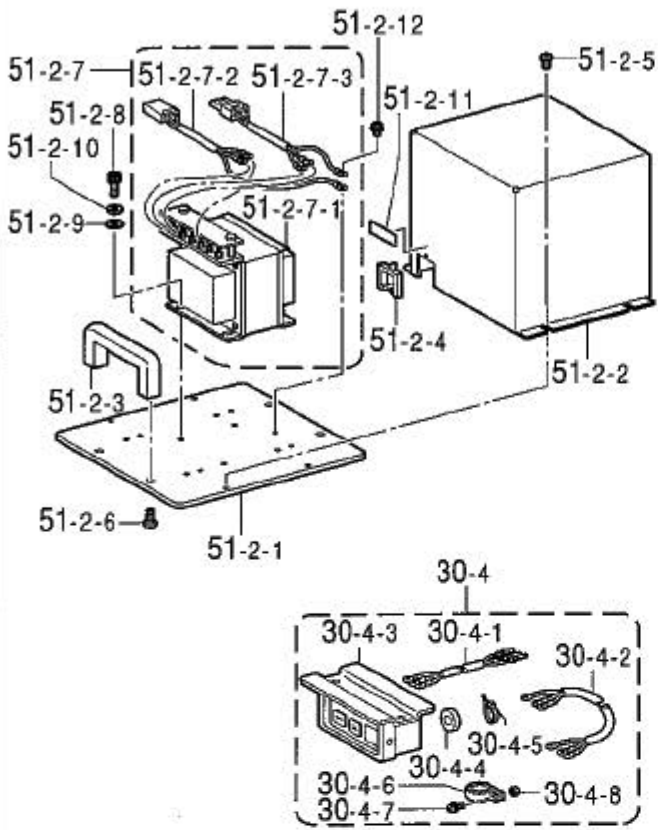

< 三相400V用 / For "3-Phase 400V AC" >

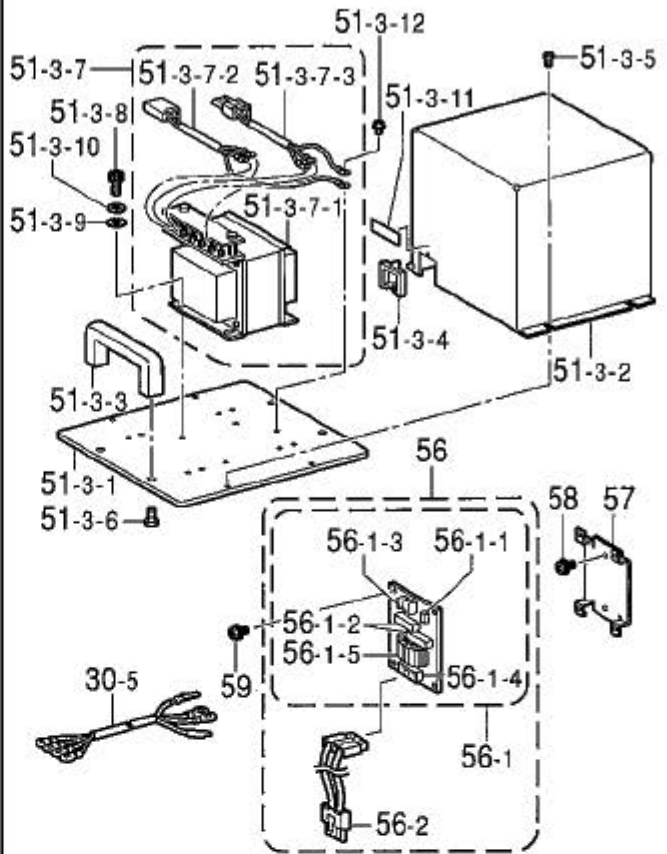

< 三相415V用 / For "3-Phase 415V AC" >

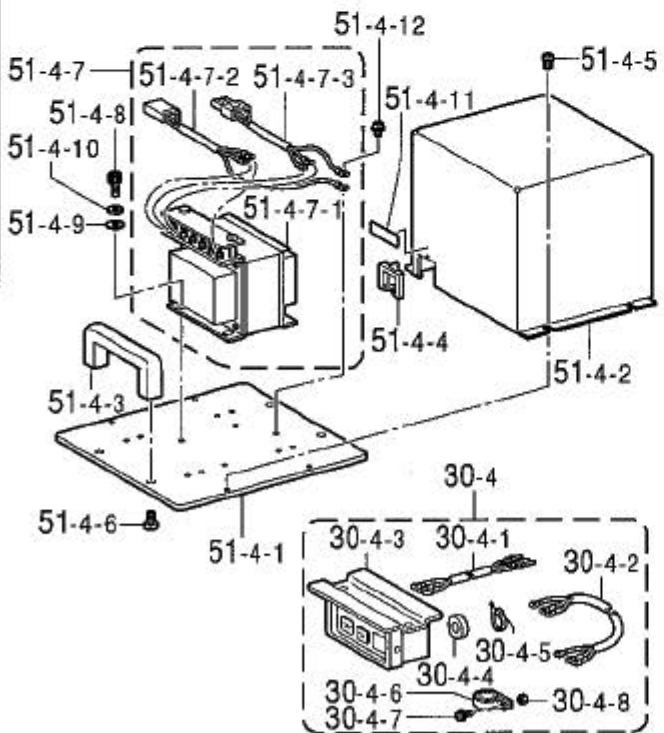

< 単相230V用 / For "1-Phase 230V AC" >

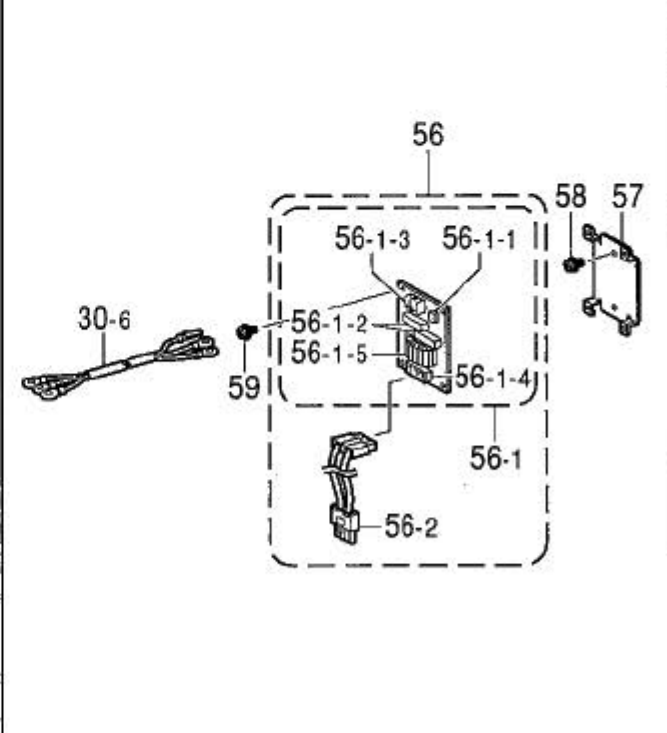

U3.コントロールボックス関係 / Control box mechanism

REF.NO	CODE	QTY	ヒンメイ	NAME OF PARTS	RM
			<三相415V用>	<For "3-Phase 415V AC">	
51-4	S50642101	1	ハンカントランスC415クミ	TRANSFORMER ASSY, C415 ;CONV.	
51-4-1	S54027001	1	トランスベース	BASE PLATE, TRANS.	
51-4-2	S54028001	1	トランスフタ	COVER, TRANS.	
51-4-3	S50474000	2	ツツ	HANDLE	
51-4-4	S41964000	1	フツシ	BUSH	
51-4-5	062500602	4	ナットM5X6	SCREW, PAN M5X6	
51-4-6	S23618001	4	シメネジM6X10	SCREW, M6X10	
51-4-7	S50643100	1	ハンカントランスC415	TRANSFORMER, C415 ;CONV.	
51-4-7-1	S38128000	1	ハンカントランスC	CONVERSION TRANSFORMER, C	
51-4-7-2	S50485100	1	TR-INケーブル	HARNESS, TR-IN	
51-4-7-3	S50486100	1	TR-OUTケーブル	HARNESS, TR-OUT	
51-4-8	018060831	4	ボルトM6X8	BOLT, SOCKET M6X8	
51-4-9	025060236	4	ワッシャーM6	WASHER, PLAIN M 6	
51-4-10	028060246	4	ワッシャーM6	WASHER, SPRING 2-6	
51-4-11	S10820007	1	テンプレート	LABEL, 415V AC	
51-4-12	0A4400606	1	ナットM4X6DA	SCREW, PAN (S/P WASHER) M4X6	
			<単相230V, 三相415V用>	<For "1-Phase 230V,3-Phase 415V AC">	
56	S50498001	1	ノイズフィルタEHクミ	NOISE FILTER ASSY, EH	
56-1	S40616001	1	ノイズフィルタEMCクミ	NOISE FILTER ASSY, EMC	
56-1-1	S40617000	1	セラミックコンデンサ102MB	CAPACITOR, CERAMIC:ECKDNA102MB	
56-1-2	S40618000	2	ポリマーコンデンサ250B474	CAPACITOR, POLYESTER :250B474	
56-1-3	S40619000	1	ターミナルブロック2P	TERMINAL BLOCK, 2P	
56-1-4	414900001	1	ヘッダー5219-03A	HEADER 5219-03A	
56-1-5	S35598000	1	コイルSC0520J	COIL, SC0520J	
56-2	S50499000	1	ノイズフィルタケーブル	NOISE FILTER HARNESS	
57	S40620000	1	基板	SETTING PLATE, ;PCB	
58	0A4400605	2	ナットM4X6DA	SCREW, PAN (S/P WASHER) M4X6	
59	0A4400605	4	ナットM4X6DA	SCREW, PAN (S/P WASHER) M4X6	

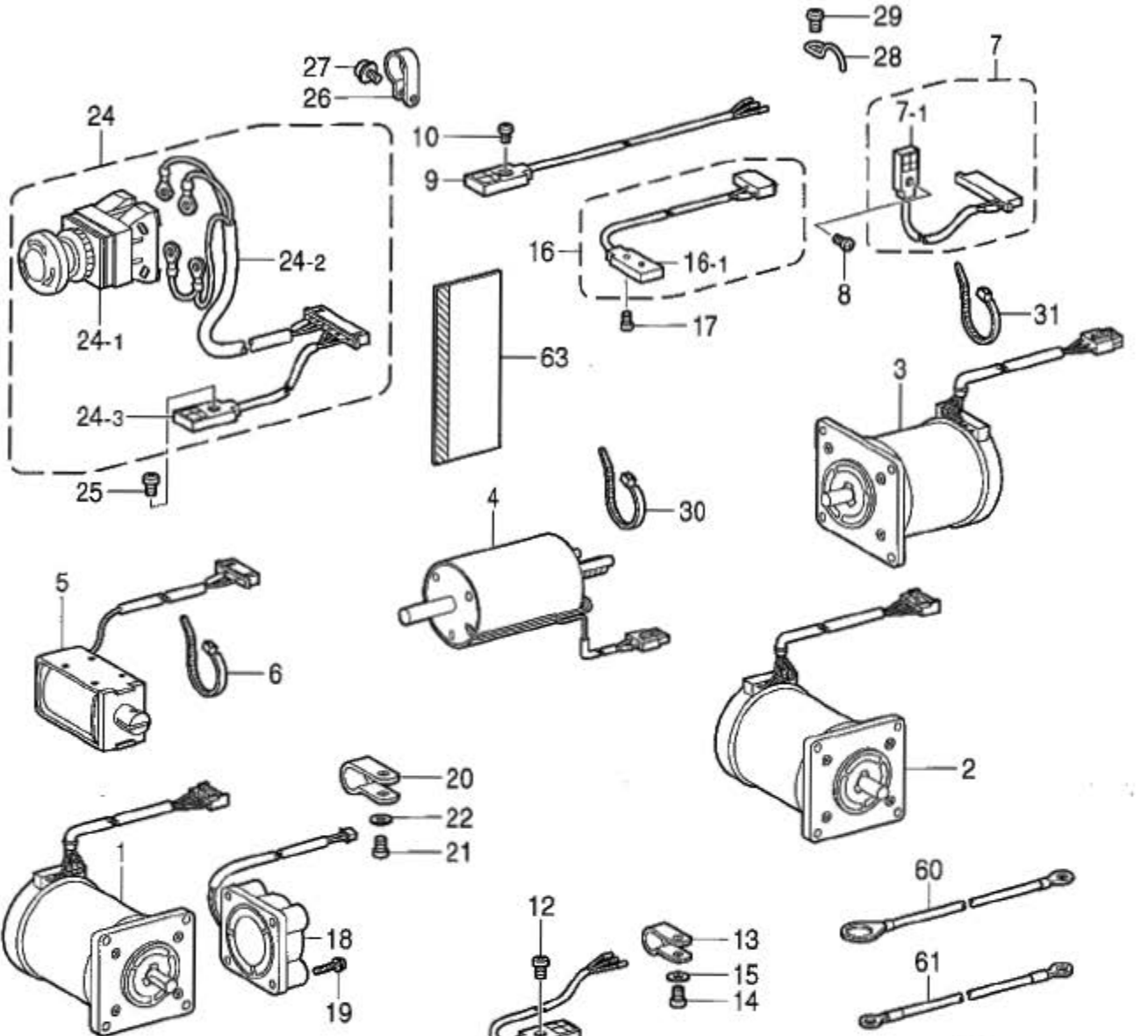

" オプション部品 / OPTION PARTS "
 < 単相230V用, 三相400V用
 / For "1-Phase 230V AC &
 3-Phase 400V AC" >

" オプション部品 / OPTION PARTS "
 < 三相400V用
 / For "3-Phase 400V AC" >

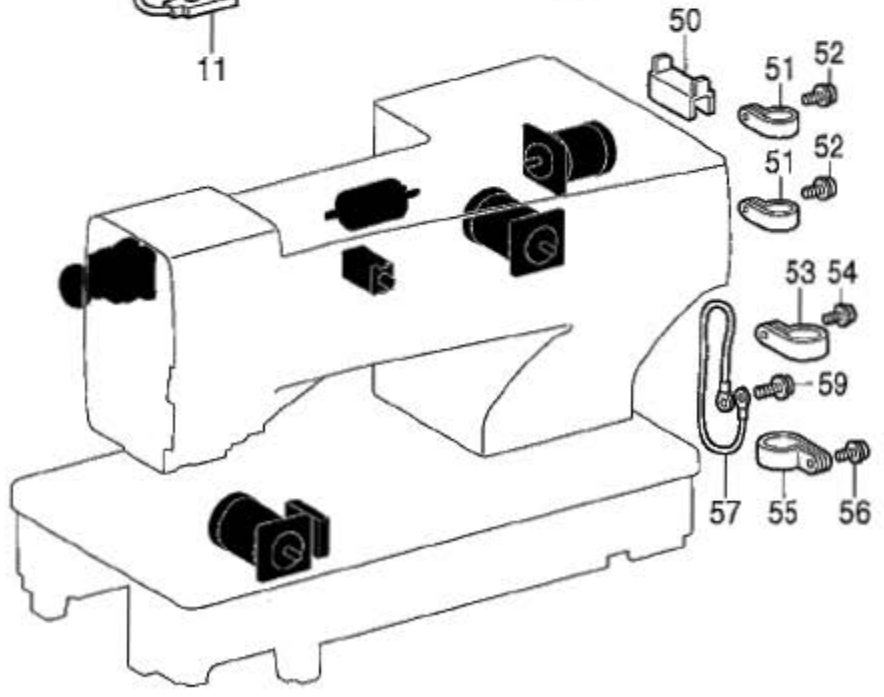

V.電装品関係 / Power supply equipment mechanism

REF.NO	CODE	QTY	ヒンメイ	NAME OF PARTS	RM
1	S50458100	1	パルスモータFDクミ	PULSE MOTOR ASSY, FD	
2	S50459100	1	パルスモータFTクミ	PULSE MOTOR ASSY, FT	
3	S50460000	1	パルスモータNクミ	PULSE MOTOR ASSY, N	
4	S50461000	1	カッターソレノイド	CUTTER SOLENOID	
5	S50462000	1	イトユルメソレノイド	TENSION RELEASE SOLENOID	
6	228475000	1	ケツクハント1.9X80	FASTENING BAND, 1.9X80	
7	S50463000	1	センサクミ	SENSOR ASSY	
7-1	S50464000	1	センサGL-N12	SENSOR, GL-N12	
8	062300806	1	ナハコ3X8	SCREW, PAN M3X8	
9	S50464000	1	センサGL-N12	SENSOR, GL-N12	
10	062300806	1	ナハコ3X8	SCREW, PAN M3X8	
11	S50465000	1	センサGL-N12	SENSOR, GL-N12	
12	062300806	1	ナハコ3X8	SCREW, PAN M3X8	
13	625010000	1	ナイロンランプNK-2N	CORD HOLDER, NK-2N	
14	062670812	1	ナハコ3.57-40X8	SCREW, PAN SM3.57-40X8	
15	025350132	1	ヒラサガネシヨウ	WASHER, PLAIN S 3.5	
16	S50466000	1	カッターセンサクミ	CUTTER SENSOR ASSY	
16-1	S50467000	1	センサGL-N12	SENSOR, GL-N12	
17	062300806	1	ナハコ3X8	SCREW, PAN M3X8	
18	S50468000	1	DCファンモータ40クミ	DC FAN MOTOR ASSY, 40	
19	0A5302005	2	ナハサクミ3X20DB	SCREW, PAN (S/P WASHER) M3X20	
20	S00480000	3	コードホルダ#5	CORD HOLDER, 5N	
21	062670812	3	ナハコ3.57-40X6	SCREW, PAN SM3.57-40X6	
22	025350132	3	ヒラサガネシヨウ	WASHER, PLAIN S 3.5	
24	S50471000	1	EMロックSWハーネスクミ	LOCK SWITCH HARNESS ASSY, EM	
24-1	S32335100	1	SW-AVS311N	SWITCH :AVS311N	
24-2	S50472000	1	EMSWハーネス	SWITC HARNESS, EM	
24-3	S50473000	1	センサGL-N12	SENSOR, GL-N12	
25	062300806	1	ナハコ3X8	SCREW, PAN M3X8	
26	S10243000	4	ナイロンランプNK-3N	CORD HOLDER, NK-3N	
27	0A5400806	4	ナハサクミ4X8DB	SCREW, PAN (S/P WASHER) M4X8	
28	152969001	1	コードサシカネ	CORD SUPPORT	
29	002300603	1	ナハコ3X6	SCREW, PAN M3X6	
30	228475000	2	ケツクハント1.9X80	FASTENING BAND, 1.9X80	
31	218859001	1	バインタM150	BINDER, M150	
50	S50565001	1	コードブッシュ	CORD BUSH	
51	552907000	2	コードホルダ#10	CORD HOLDER, 10N	
52	0A5401006	2	ナハコハネヒラ4X10	SCREW, PAN (S/P WASHER) M4X10	
53	552908000	1	コードホルダ#14	CORD HOLDER, 14N	
54	0A5401006	1	ナハコハネヒラ4X10	SCREW, PAN (S/P WASHER) M4X10	
55	552908000	1	コードホルダ#14	CORD HOLDER, 14N	
56	0A5401006	1	ナハコハネヒラ4X10	SCREW, PAN (S/P WASHER) M4X10	
57	S38145000	1	アースセン2	GROUND WIRE, 2	
59	0A5401006	2	ナハコハネヒラ4X10	SCREW, PAN (S/P WASHER) M4X10	
60	S41216000	1	アースセン	GROUND WIRE	
61	S50644000	1	アースコード	GROUND WIRE	
63	SA0287000	1	クイツクチューブ 30X350	TUBE, 30X350	
			"オプション部品"	"OPTION PARTS"	
			<単相230V, 三相400V用>	<For "1-Phase 230V,3-Phase 400V AC">	
23	S37055001	1	EMスイッチスハサ	SPACER, 1 ;EM-SWITCH	
900	S42653000	1	コアTFC-23-11-14	CORE :TFC-23-11-14	
901	S40623000	3	EMIコアTR-40-27	EMI CORE, TR-40-27	
902	0A5401206	3	ナハサクミ4X12DB	SCREW, PAN (S/P WASHER) M4X12	
903	021400106	3	ナット1シユ4	NUT, 1 M4	
			<三相400V用>	<For "3-Phase 400V AC">	
904	S40623000	1	EMIコアTR-40-27	EMI CORE, TR-40-27	
905	0A5401206	1	ナハサクミ4X12DB	SCREW, PAN (S/P WASHER) M4X12	
906	021400106	1	ナット1シユ4	NUT, 1 M4	

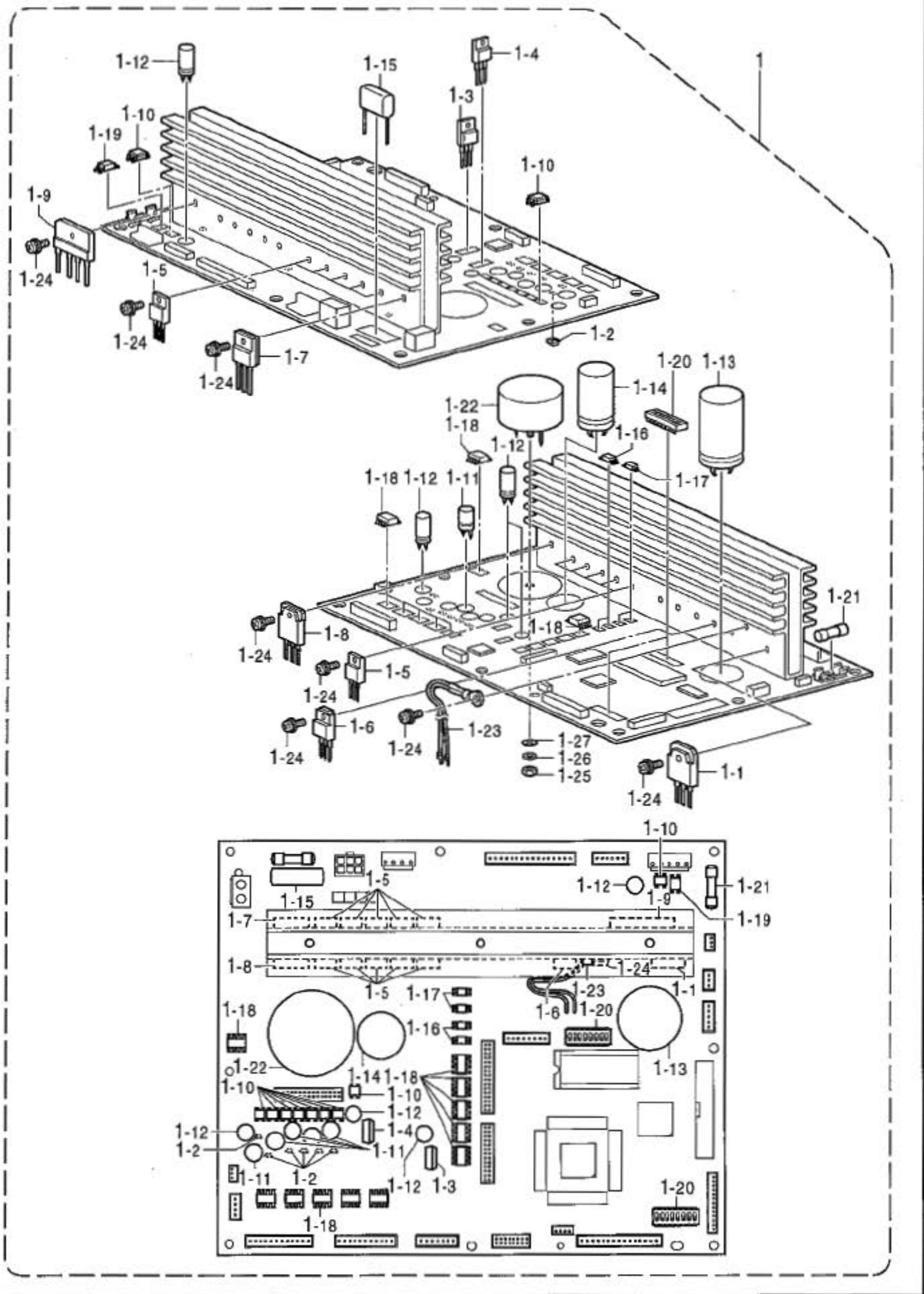

W.プリント基板関係 / Printed circuit board mechanism

REF.NO	CODE	QTY	ヒンメイ	NAME OF PARTS	RM
1	S53902301	1	基板コネクタハンダ	MAIN PCB ASSY	
1-1	S08047000	1	BIBICS1-3052V	REGULATOR, :SI3052V	
1-2	S47664000	6	レギュレータAN78L18M	REGULATOR, :AN78L18M	
1-3	S47665000	1	レギュレータAN78M18F	REGULATOR, :AN78M18F	
1-4	S46454000	1	レギュレータTA7810S	REGULATOR, :TA7810S	
1-5	S46455000	10	FETFK10KM-10	TRANSISTOR, FET :FK10KM-10	
1-6	S38155000	1	MOSFET2SK1306	TRANSISTOR, FET :2SK1306	
1-7	S38200000	1	MOSFET2SK1938	TRANSISTOR, :2SK1938	
1-8	S47668000	1	SIDPA905C6	DIODE, AR :PA905C6	
1-9	S47669000	1	DBRD5SB20	DIODE, BR :D5SB20	
1-10	S47670000	9	SIDS1ZB60	DIODE, BR :SIZB60	
1-11	Y42215591	5	コンデンサC50B221	CAPACITOR, ALUM-ELEC :50B221	
1-12	Y44715591	4	コンデンサC50B471	CAPACITOR, ALUM-ELEC :50B471	
1-13	S47673000	1	コンデンサC80B472	CAPACITOR, ALUM-ELEC :50B472	
1-14	S47678000	1	コンデンサC450B101	CAPACITOR, ALUM-ELEC :450B101	
1-15	S30209000	1	フィルムC400B105	CAPACITOR, POLYESTER :400B105	
1-16	S30205000	2	フォトカプラTLP112A	PHOTO COUPLER, :TLP112A	
1-17	S42699000	2	フォトカプラTLP121	PHOTO COUPLER, :TLP121	
1-18	S43178000	11	フォトカプラPC9231	PHOTO COUPLER, :PC9231	
1-19	J02621001	1	フォトカプラTLP120	PHOTO COUPLER, :TLP120	
1-20	U32744000	2	DIPSWDSS708	DIP SWITCH:DSS708	
1-21	S47680000	1	GFUSE8A	GLASS FUSE, 8A	
1-22	S47681000	1	コイルSK40S120-700	COIL, :SK40S120-700	
1-23	S58731000	1	サーミスタ	THERMISTOR ASSY	
1-24	0A4301005	19	ネジM3X10DA	SCREW, PAN (S/P WASHER) M3X10	
1-25	021300206	1	ナットM3	NUT, 2 M3	
1-26	028030246	1	ワッシャーM3-3	WASHER, SPRING 2-3	
1-27	025030136	1	ワッシャーM3	WASHER, PLAIN S 3	

X1. 付属装置関係 (オプション部品) / Attachment set (Option parts)

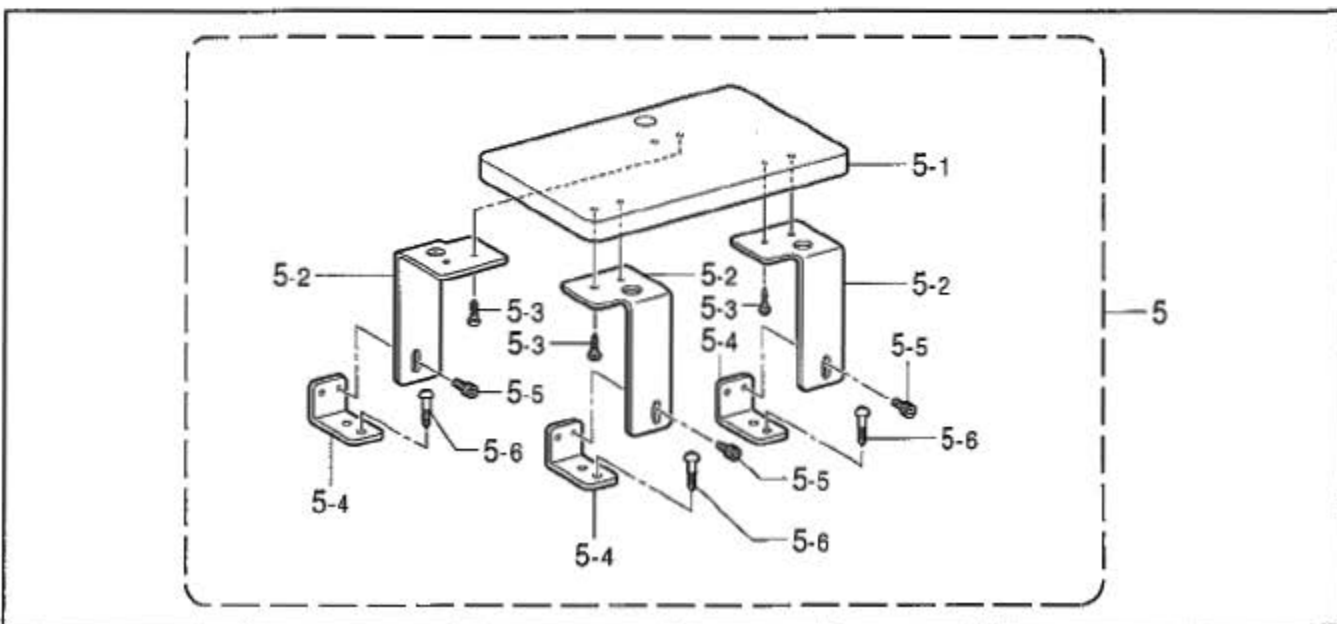
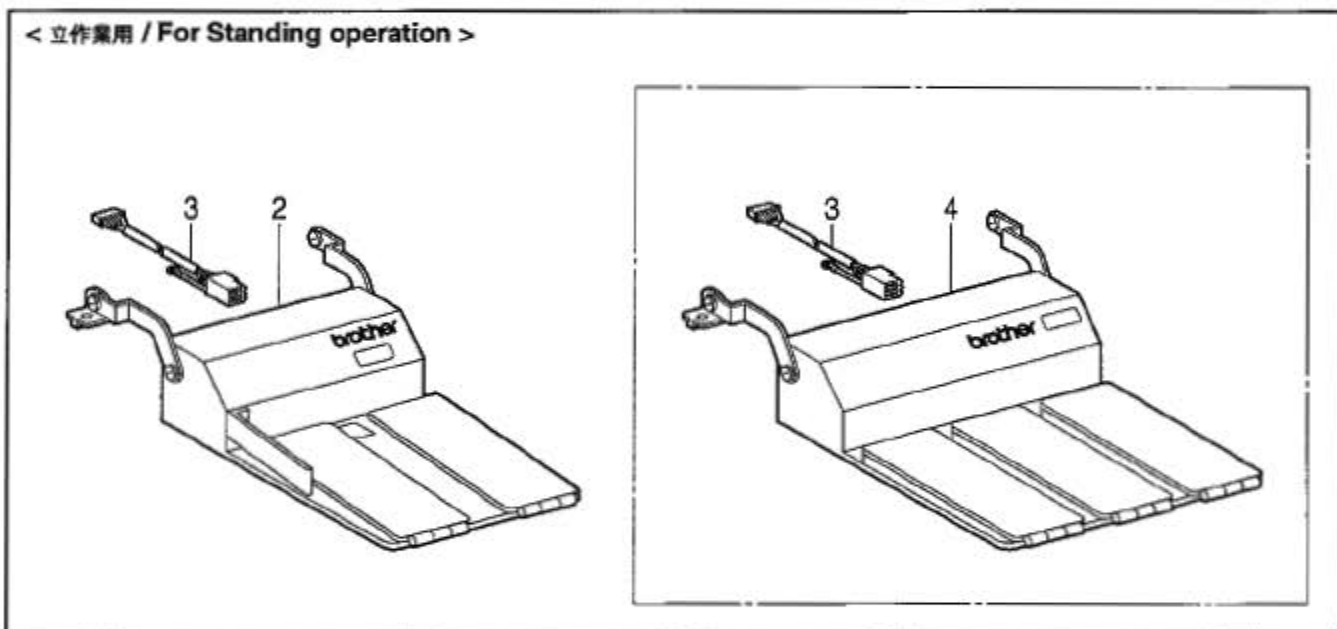
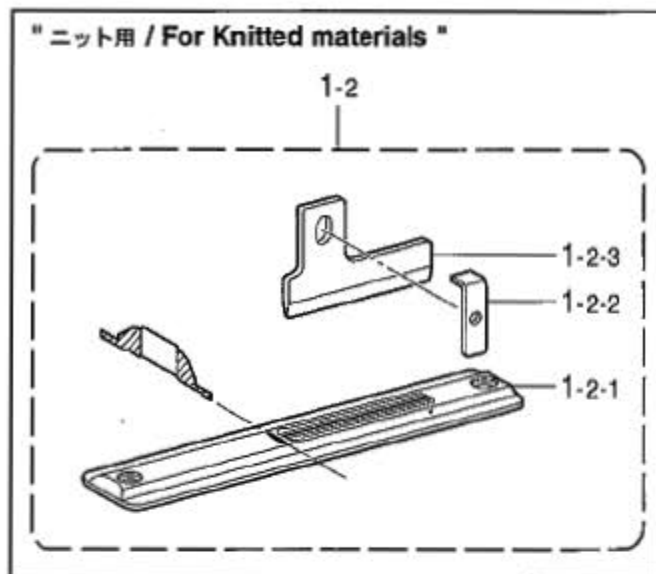
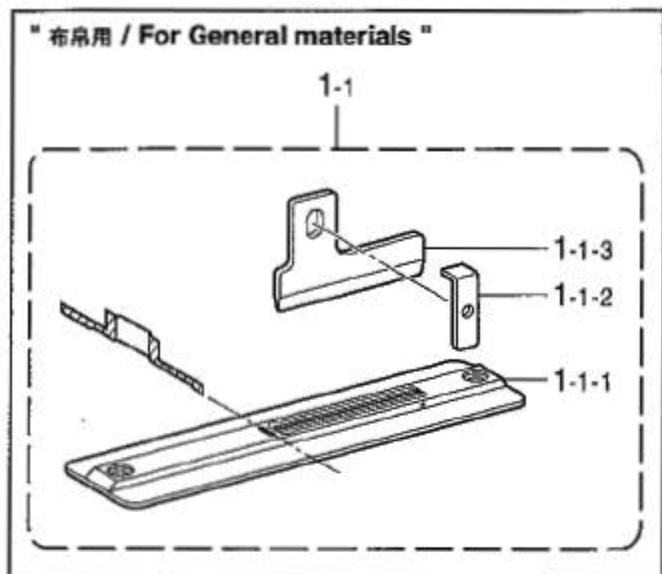

X1. 付属装置関係 (オプション部品) / Attachment set (Option parts)

REF.NO	CODE	QTY	ヒンメイ	NAME OF PARTS	RM
1-1	S51361001	1	"布帛用" <針穴: 1.2X5.4mm> ハリイタ1.2RBセツト	"For General materials" <Needle hole : 1.2X5.4mm> NEEDL PLATE SET, 1.2RB	
1-1-1	S50304001	1	ハリイタ1.2S-RBカミ	NEEDLE PLATE ASSY, 1.2S-RB	
1-1-2	S50297001	1	カッターサシ	CUTTER HOLDER	
1-1-3	S50341001	1	カッター補助イキメタ	POSITIONING PLATE	
1-1	S51362001	1	<針穴: 1.4X7.3mm> ハリイタ1.4RBセツト	<Needle hole : 1.4X7.3mm> NEEDLE PLATE SET, 1.4RB	
1-1-1	S50309001	1	ハリイタ1.4S-RBカミ	NEEDLE PLATE ASSY, 1.4S-RB	
1-1-2	S50297001	1	カッターサシ	CUTTER HOLDER	
1-1-3	S50341001	1	カッター補助イキメタ	POSITIONING PLATE	
1-1	S51363001	1	<針穴: 1.6X7.3mm> ハリイタ1.6RBセツト	<Needle hole : 1.6X7.3mm> NEEDLE PLATE SET, 1.6RB	
1-1-1	S50311001	1	ハリイタ1.6S-RBカミ	NEEDLE PLATE ASSY, 1.6S-RB	
1-1-2	S50297001	1	カッターサシ	CUTTER HOLDER	
1-1-3	S50341001	1	カッター補助イキメタ	POSITIONING PLATE	
1-2	S51364001	1	"ニット用" <針穴: 1.2X5.4mm> ハリイタ1.2RB-3セツト	"For knitted materials" <Needle hole : 1.2X5.4mm> NEEDLE PLATE SET, 1.2RB-3	
1-2-1	S50313101	1	ハリイタ1.2S-RBカミ-3	NEEDLE PLATE ASSY, 1.2-RB-3	
1-2-2	S50297001	1	カッターサシ	CUTTER HOLDER	
1-2-3	S50341001	1	カッター補助イキメタ	POSITIONING PLATE	
1-2	S51365001	1	<針穴: 1.4X6.8mm> ハリイタ1.4RB-3セツト	<Needle hole : 1.4X6.8mm> NEEDLE PLATE SET, 1.4RB-3	
1-2-1	S50317101	1	ハリイタ1.4S-RBカミ-3	NEEDLE PLATE ASSY, 1.4S-RB-3	
1-2-2	S50297001	1	カッターサシ	CUTTER HOLDER	
1-2-3	S50341001	1	カッター補助イキメタ	POSITIONING PLATE	
1-2	S51366001	1	<針穴: 1.6X6.8mm> ハリイタ1.6RB-3セツト	<Needle hole : 1.6X6.8mm> NEEDLE PLATE SET, 1.6RB-3	
1-2-1	S50319101	1	ハリイタ1.6S-RBカミ-3	NEEDLE PLATE ASSY, 1.6S-RB-3	
1-2-2	S50297001	1	カッターサシ	CUTTER HOLDER	
1-2-3	S50341001	1	カッター補助イキメタ	POSITIONING PLATE	
2	J80081040	1	<立作業用> DDタチハタル40カハン#6	<For Standing operation> STANDING OPERATION 2-PEADL, #6	
3	S47750000	1	<2,3連ハタリ用> タチハタルヨウネ	<For 2 & 3 -pedal> HARNESS, ;S-OPE.	
4	J80380040	1	DDタチハタル3Pカハン40	STANDING OPERATION 3-PEDAL, #40	
5	S53996101	1	サシヨテブルカミ	AUXILIARY TABLE ASSY	
5-1	S53997000	1	サシヨテブル	AUXILIARY TABLE	
5-2	S53998001	3	サシヨテブルサシ	AUX. TABLE SUPPORT	
5-3	031351006	6	+マルモクネシ 3.5X10	WOOD SCREW, ROUND M3.5X10	
5-4	S13650001	3	シオクリウテD	BOTTOM FEED ARM, D	
5-5	018680822	3	アサボルト4.37X8	BOLT, SOCKET SM4.37X8	
5-6	032422003	3	+マルモクネシ 4.1X20	WOOD SCREW, ROUND M4.1X20	

X2. 付属装置関係 (オプション部品) / Attachment set (Option parts)

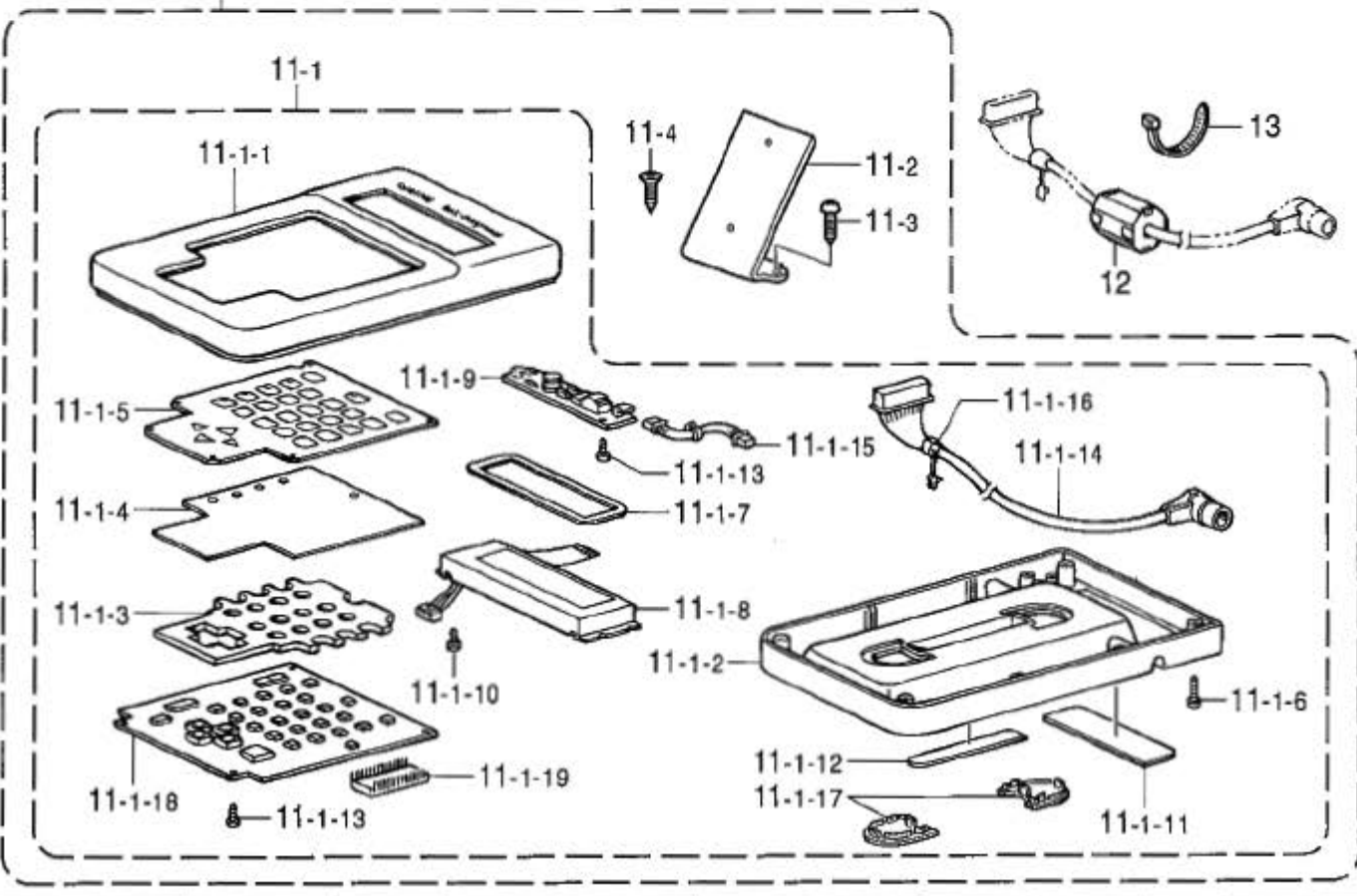
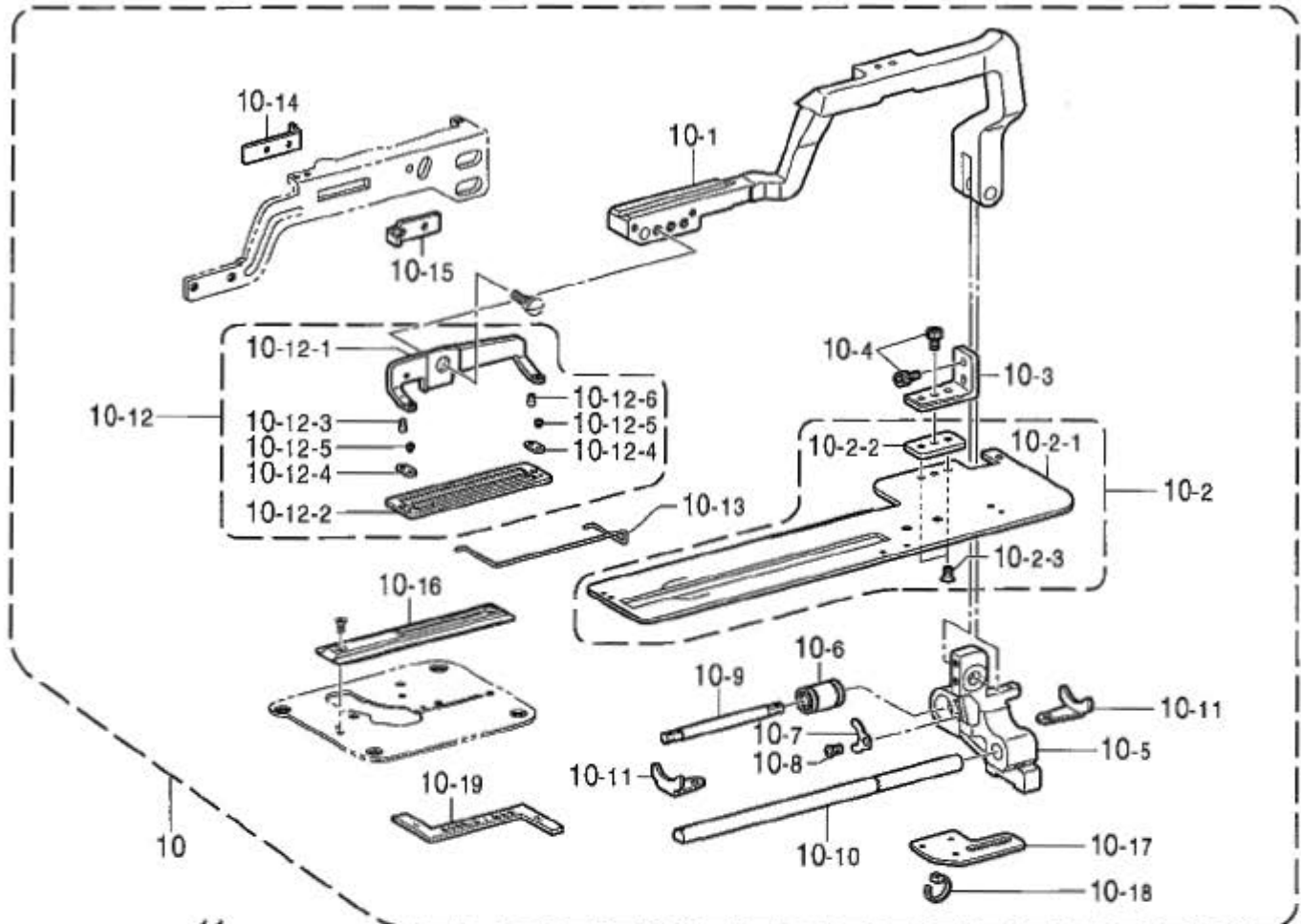

X2. 付属装置関係 (オプション部品) / Attachment set (Option parts)

REF.NO	CODE	Q'TY	ヒンメイ	NAME OF PARTS	RM
10	S54501101	1	クミカ工 ^レ ヒンセット-70	EXCHANGE PARTS SET, -70	
10-1	S54503001	1	オリウテ ^レ -5	FEED ARM, 5	
10-2	S54504001	1	ナカ ^レ サクリイタ ^レ -5クミ	LENGTH FEED PLATE ASSY, -5	
10-2-1	S54505001	1	ナカ ^レ サクリイタ ^レ -5	LENGTH FEED PLATE, -5	
10-2-2	S54506001	1	オリイタス ^レ ハ ^レ -サ	SPACER, ;FEED PLATE	
10-2-3	117160001	2	サラネシ ^レ 4. 37	SCREW, FLAT SM4.37	
10-3	S54507001	1	オリイタササ ^レ イ ^レ タ	FEED PLATE SUPPORT	
10-4	018680822	2	アホ ^レ ボ ^レ ボ ^レ 4. 37X8	BOLT, SOCKET SM4.37X8	
10-5	S54508001	1	オリウテ ^レ ササ ^レ イ ^レ タ ^レ -1-5	FEED ARM SUPPORT, -5	
10-6	S54509000	1	リニア ^レ ブ ^レ ツシ ^レ 9, 53	LINEAR BUSH, 9.53	
10-7	S54510001	1	リニア ^レ ブ ^レ ツシ ^レ ト ^レ メ ^レ イ ^レ タ	STOPPER PLATE, L-BUSH	
10-8	062680612	1	ナ ^レ ハ ^レ コ ^レ 4. 37-40X6	SCREW, PAN SM4.37-40X6	
10-9	S54511001	1	オリアン ^レ ナイ ^レ シ ^レ ク ^レ A-5	SHAFT, A-5 ;F-GUIDE	
10-10	S54512001	1	オリアン ^レ ナイ ^レ シ ^レ ク ^レ B-5	SHAFT, B-5 ;F-GUIDE	
10-11	S54513001	2	タマ ^レ シ ^レ ク ^レ ケ ^レ ト ^レ メ ^レ イ ^レ タ ^レ B	STOPPER PLATE, B ;B-BEARING	
10-12	S54514101	1	ヌ ^レ ツ ^レ カ ^レ ミ ^レ 70クミ	WORK CLAMP ASSY, 70	
10-12-1	S54515001	1	ヌ ^レ ツ ^レ カ ^レ ミ ^レ 70	WORK CLAMP, 70	
10-12-2	159926001	1	ヌ ^レ ツ ^レ カ ^レ ミ ^レ サ ^レ サ ^レ エ ^レ ビ ^レ ン ^レ L	PIN, L	
10-12-3	107401001	2	ヌ ^レ ツ ^レ カ ^レ ミ ^レ サ ^レ サ ^レ エ ^レ イ ^レ タ ^レ ハ ^レ ネ	SPRING, PLATE	
10-12-4	107404001	2	シ ^レ メ ^レ ネ ^レ シ ^レ 1. 98	SCREW, SM1.98-64X2	
10-12-5	S54987001	1	ヌ ^レ ツ ^レ カ ^レ ミ ^レ サ ^レ サ ^レ エ ^レ ビ ^レ ン ^レ F	PIN, F	
10-12-6	S54516101	1	ヌ ^レ ツ ^レ カ ^レ ミ ^レ サ ^レ サ ^レ エ ^レ	WORK CLAMP HOLDER	
10-13	S54517000	1	フ ^レ イ ^レ ン ^レ ガ ^レ ー ^レ カ ^レ ー ^レ ト ^レ 70	FINGER GUARD, 70	
10-14	S54520001	1	ハ ^レ サ ^レ ミ ^レ モ ^レ ト ^レ リ ^レ ト ^レ メ ^レ イ ^レ タ ^レ B	STOP PLATE, B	
10-15	S54521001	1	ハ ^レ サ ^レ ミ ^レ モ ^レ ト ^レ シ ^レ イ ^レ タ ^レ B	BACK PLATE, B	
10-16	S54522001	1	ハ ^レ リ ^レ イ ^レ タ ^レ 1. 4-50	NEEDLE PLATE, 1.4-50	
10-17	S50215101	1	オリ ^レ セン ^レ サ ^レ サ ^レ エ ^レ イ ^レ タ	SUPPORT PLATE, FEED SENSOR	
10-18	228475000	1	ケ ^レ ツ ^レ ク ^レ ハ ^レ ント ^レ 1. 9X80	FASTENING BAND, 1.9X80	
10-19	S13597101	1	テ ^レ ア ^レ イ ^レ ゲ ^レ ー ^レ ジ ^レ -5/BAS	GAUGE, -5/BAS	
			<国内用>		
11	S58988001	1	プ ^レ ロ ^レ グ ^レ ラ ^レ マ ^レ セ ^レ ト ^レ A1	PROGRAMMER SET, A1	
			<輸出用>	<For export>	
11	S58989001	1	プ ^レ ロ ^レ グ ^レ ラ ^レ マ ^レ セ ^レ ト ^レ A2	PROGRAMMER SET, A2	
11-1	S58971001	1	プ ^レ ロ ^レ グ ^レ ラ ^レ マ ^レ -グ ^レ ミ ^レ A	PROGRAMMER ASSY, A	
11-1-1	S43250100	1	プ ^レ ロ ^レ グ ^レ ラ ^レ マ ^レ -ウ ^レ イ ^レ タ	TOP COVER, PROGRAMMER	
11-1-2	S43251000	1	プ ^レ ロ ^レ グ ^レ ラ ^レ マ ^レ -シ ^レ タ ^レ フ ^レ タ	LOWER COVER, PROGRAMMER	
11-1-3	S43252000	1	キ ^レ ホ ^レ ー ^レ ト ^レ ス ^レ ハ ^レ -サ	SPACER, KEYBOARD	
11-1-4	S43253000	1	キ ^レ ホ ^レ ー ^レ ト ^レ ゴ ^レ ム ^レ シ ^レ ト	RUBBER SHEET, KEYBOARD	
11-1-5	S58972000	1	キ ^レ ホ ^レ ー ^レ ト ^レ シ ^レ ト	KEYBOARD SHEET	
11-1-6	037301015	4	V ^レ ナ ^レ ハ ^レ タ ^レ ビ ^レ ン ^レ 3X10	TAPPING SCREW, PAN V M3X10	
11-1-7	S43255000	1	LCDカ ^レ ハ ^レ -	LCD COVER	
11-1-8	S43256000	1	LCD	LCD	
11-1-9	S43257000	1	LCDヨ ^レ ウ ^レ イ ^レ ン ^レ バ ^レ -タ ^レ -	INVERTER, LCD	
11-1-10	037200615	4	V ^レ ナ ^レ ハ ^レ タ ^レ ビ ^レ ン ^レ 2X6	TAPPING SCREW, PAN V M2X6	
11-1-11	S43271000	1	プ ^レ ロ ^レ グ ^レ ラ ^レ マ ^レ -マ ^レ グ ^レ ネ ^レ ト ^レ A	MAGNET, A	
11-1-12	S43272000	1	プ ^レ ロ ^レ グ ^レ ラ ^レ マ ^レ -マ ^レ グ ^レ ネ ^レ ト ^レ B	MAGNET, B	
11-1-13	037300615	6	V ^レ ナ ^レ ハ ^レ タ ^レ ビ ^レ ン ^レ 3X6	TAPPING SCREW, PAN V M3X6	
11-1-14	S43267000	1	プ ^レ ロ ^レ グ ^レ ラ ^レ マ ^レ -ユ ^レ ト ^レ	PROGRAMMER HARNESS	
11-1-15	S43268000	1	イ ^レ ン ^レ バ ^レ -タ ^レ -ハ ^レ ネ ^レ ス	INVERTER HARNESS	
11-1-16	S43270000	1	ユ ^レ ト ^レ ブ ^レ ツ ^レ シ ^レ ク ^レ KR51	CORD BUSH, KR51	
11-1-17	S43981000	2	プ ^レ ロ ^レ グ ^レ ラ ^レ マ ^レ -シ ^レ タ ^レ カ ^レ ハ ^レ -	UNDER COVER, PROGRAMMER	
11-1-18	S58978001	1	プ ^レ ロ ^レ グ ^レ ラ ^レ マ ^レ キ ^レ ハ ^レ ン ^レ ク ^レ ミ ^レ A	PROGRAMMER PCB ASSY, A	
11-1-19	S58973000	1	PROMプ ^レ ロ ^レ グ ^レ ラ ^レ マ ^レ ク ^レ ミ	PROM PROGRAMMER ASSY	
11-2	S42890001	1	プ ^レ ロ ^レ グ ^レ ラ ^レ マ ^レ サ ^レ サ ^レ エ ^レ	PROGRAMMER SUPPORT	
11-3	032422003	2	+マル ^レ モ ^レ ク ^レ ネ ^レ シ ^レ 4. 1X20	WOOD SCREW, ROUND M4.1X20	
11-4	0B1351606	2	+サ ^レ ラ ^レ モ ^レ ク ^レ 35X16	WOOD SCREW, FLAT M3.5X16	
12	S40621000	1	EMIコ ^レ ア ^レ ESD-SR-15	EMI CORE, ESD-SR-15	
13	149809000	1	タイ ^レ ラ ^レ ツ ^レ ブ ^レ L	BEAD BAND, L=200	

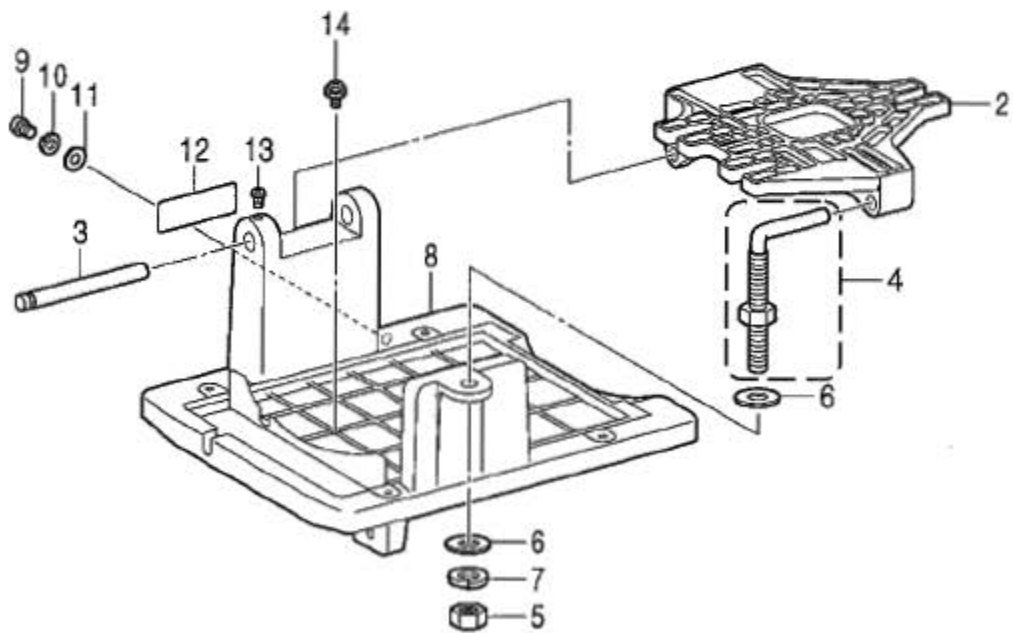
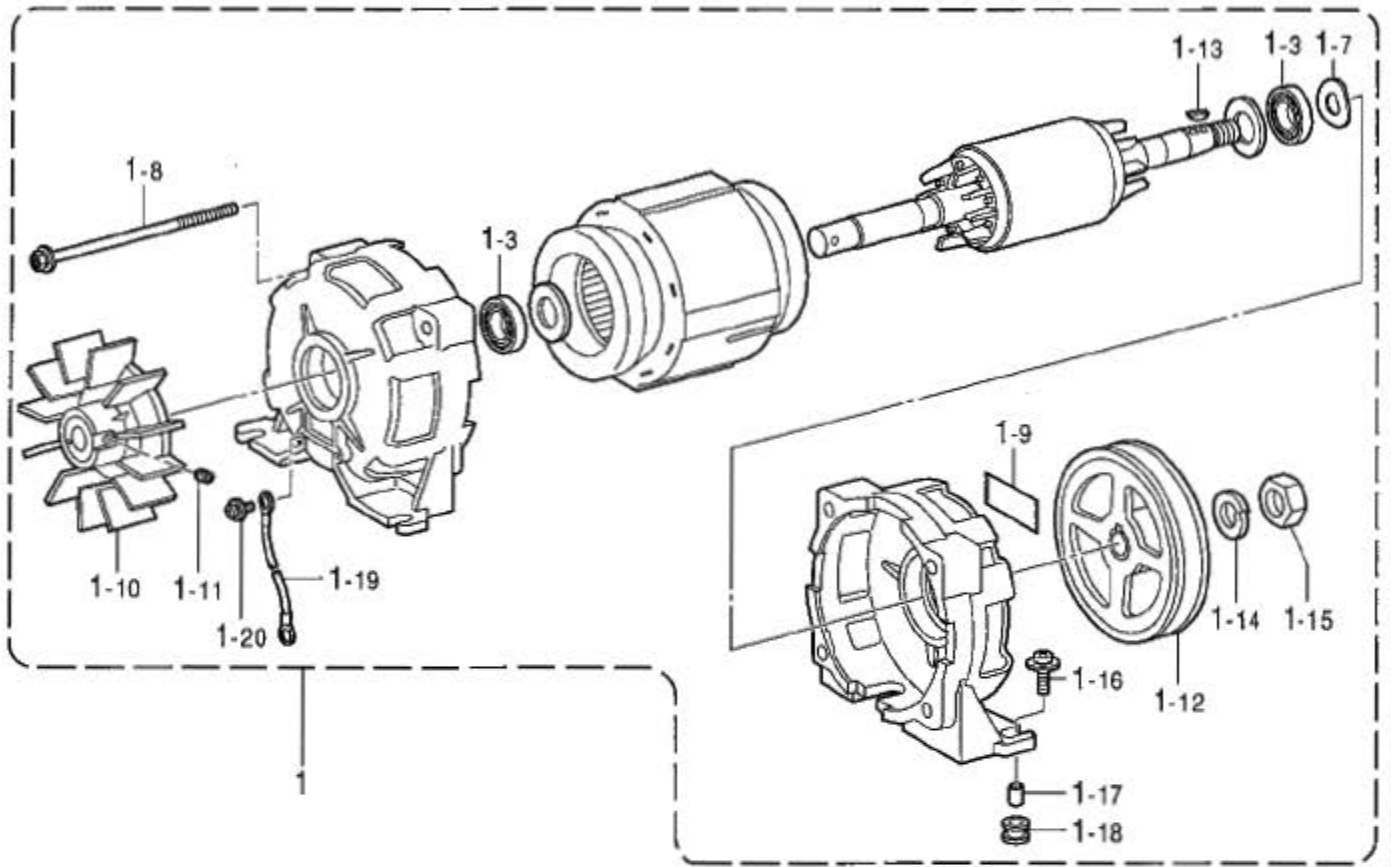

Y. モーター関係 / Moter mechanism

REF.NO	CODE	QTY	品名	NAME OF PARTS	RM
1	J80863001	1	EHモーター240V/400V	MOTOR ASSY, EH 240V/400W	
1-2	-----	1	ロータリINV	ROTOR ASSY, INV	
1-3	076202801	2	タマシクウケ6202ZZ	BALL BEARING, 6202ZZ	
1-4	-----	1	スタキセンクミINV#2	STATOR ASSY, INV-#2	
1-5	-----	1	モーターラケットINV#3M	MOTOR BRACKET, INV-#3M	
1-6	-----	1	モーターラケットINV#3E	MOTOR BRACKET, INV-#3E	
1-7	203684001	11	ナミ703X27.5X34.9	WASHER WAVE M 0.3X27.5X34.9	
1-8	J02537001	4	6カクサクミ5X110DB	BOLT, HEX (S/P WASHER) M5X110	
1-9	-----	1	モーターメハINV	NAME PLATE, MOTOR-INV	
1-10	J02525001	1	モーターファンINV	MOTOR FAN, INV	
1-11	014500632	1	アナクホミM5X6	SET SCREW, SOCKET (CP) M5X6	
1-12	J02278001	1	プーリQ90	PULLEY, Q90	
1-13	216205000	1	ハンケツキ4X13#2	KEY, 4X13#2	
1-14	028100246	1	ハネサカネ2-10	WASHER, SPRING 2-10	
1-15	J02493001	1	3シュナツトM10X1.0	NUT, 3M10X1.0	
1-16	J03457001	4	ナハコセツ5X20DC	SCREW, PAN (S/P WASHER) M5X20	
1-17	J02989001	4	カラーD5.1XT0.6XL9	COLLOR, D51XT0.6XL9	
1-18	J02991001	4	ホウシゴミINV	RUBBER CUSHION, INV	
1-19	J02990001	1	モータースコットクミ	GROUND WIRE ASSY, MOTOR	
1-20	229017001	1	ナハコセツ4X10DA	SCREW, PAN (S/P WASHER) M4X10	
2	J00107001	1	MD806コテタイ#2	BASE, MD806#2	
3	J02517001	1	ピン9.9X116	PIN, 9.9X116	
4	J03275001	1	カクサクミ10X10-V	BOLT ASSY, LM10-V	
5	021100206	1	2シュナツト10	NUT, 2M10	
6	025100236	2	ヒラサカネチユウ10	WASHER, PLAIN M 10	
7	028100246	1	ハネサカネ2-10	WASHER, SPRING 2-10	
8	J03410001	1	EZモーターリツケイタ	SETTING PLATE, EZ-MOTOR	
9	062401063	1	ナハコ4X10	SCREW, PAN M4X10	
10	028040245	1	ハネサカネ2-4	WASHER, SPRING 2-4	
11	025040173	1	ヒラサカネチユウ4	WASHER, PLAIN S 4	
12	-----	1	メハンモーターEH	NAME PLATE, EH	
13	002401006	1	ナハコ4X10	SCREW, PAN M4X10	
14	229017001	1	ナハコセツ4X10DA	SCREW, PAN (S/P WASHER) M4X10	

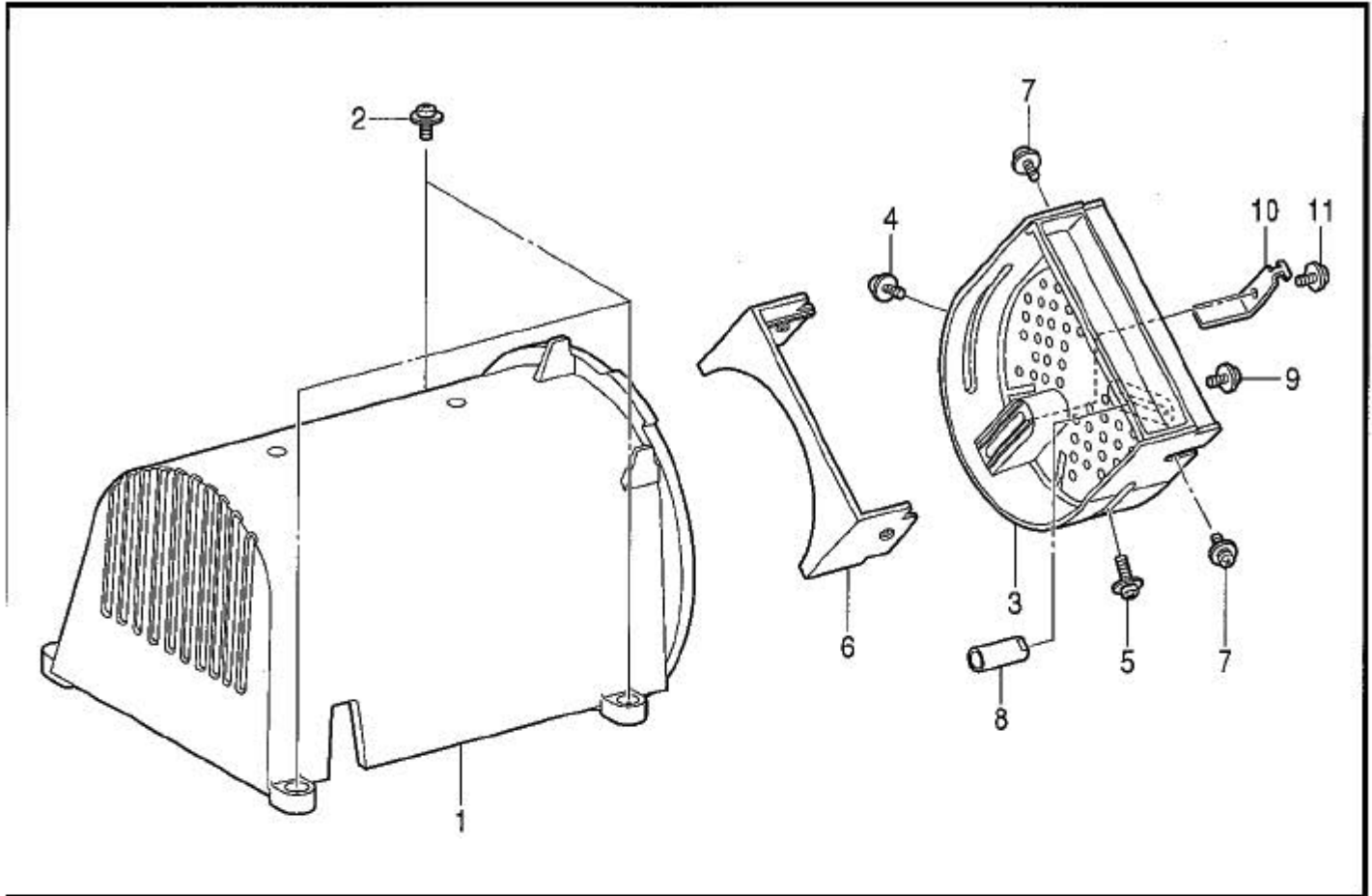

118-H80(137-611)

Z1 . 付属品関係 / Accessories

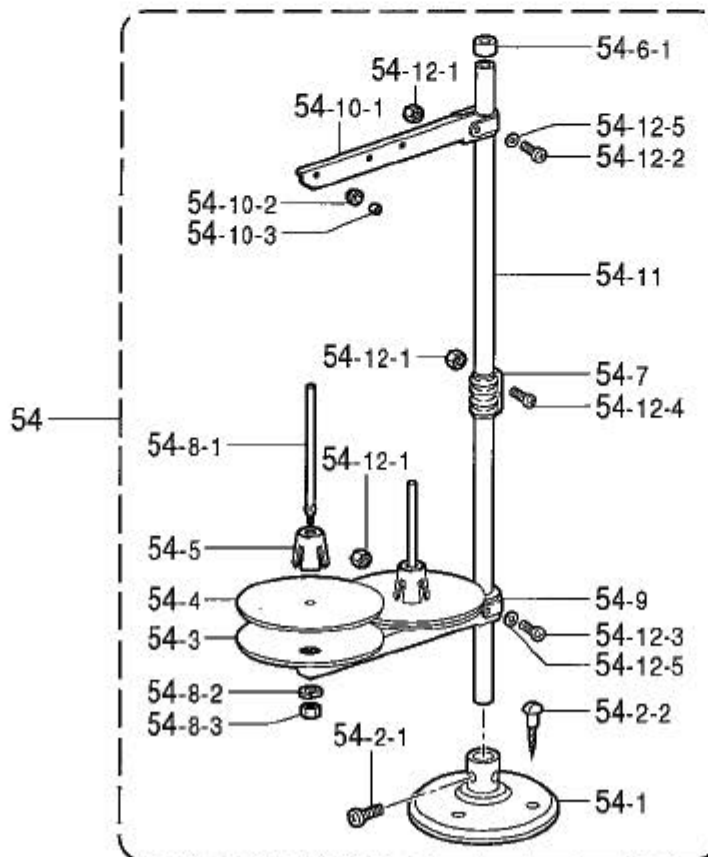

118-H80-910

AA.カバー関係 / Safety cover

REF.NO	CODE	Q'TY	ヒンメイ	NAME OF PARTS	RM
1	J02513001	1	モータカバー-INV	MOTOR COVER, INV	
2	J00494001	3	ナットセット4X14DA	SCREW, PAN (S/P WASHER) M4X14	
3	J02515001	1	ベルトカバー-INV	BELT COVER ASSY, INV	
4	224508001	1	ナットセット4X10DC	SCREW, PAN (S WASHER) M4X10	
5	217071001	1	ナットセット4X18DA	SCREW, PAN (S/P WASHER) M4X18	
6	J02516001	1	ベルトカバー-INV	BELT COVER, SUB INV	
7	224508001	2	ナットセット4X10DC	SCREW, PAN (S WASHER) M4X10	
8	J02293001	1	指保護棒	FINGER PROTECTION BAR	
9	224508001	1	ナットセット4X10DC	SCREW, PAN (S WASHER) M4X10	
10	J00351001	1	ベルトホルダーレギュレーション2	BELT HOLDER, 2	
11	224508001	1	ナットセット4X10DC	SCREW, PAN (S WASHER) M4X10	

118-H80(137-611)

Z1. 付属品関係 / Accessories

REF.NO	CODE	Q'TY	ヒンメイ	NAME OF PARTS	RM
54	S02761309	1	コットンスタンドイグニッション	COTTON STAND ASSY, 2	
54-1	150189109	1	ブラケット	COTTON STAND BRACKET	
54-2	S02773001	1	ブラケットネジセット	C-STAND BRACKET & SCREW SET	
54-2-1	062060806	2	ナットM6X8	SCREW, PAN M6X8	
54-2-2	031452206	3	丸木ネジM4.5X22	WOOD SCREW, ROUND M4.5X22	
54-3	S51283001	2	スプール	SPOOL STAND BASE	
54-4	150182000	2	スプールマット	SPOOL MAT	
54-5	S51282001	2	スプールクッション	SPOOL CUSHION	
54-6	S40639001	1	コラムパイプキャップ付き	COLUMN PIPE W/CAP	
54-6-1	150174000	1	コラムキャップ	COLUMN CAP	
54-7	150173003	1	コラムジョイント	COLUMN JOINT	
54-8	S21798001	2	スプールネジセット	SPOOL & SCREW SET	
54-8-1	150179002	2	スプールシャフトB	SPOOL SHAFT, B	
54-8-2	028050246	2	ワッシャー、スプリング2-5	WASHER, SPRING 2-5	
54-8-3	021500106	2	ナットM5	NUT, 1 M5	
54-9	S02778002	1	スプールホルダー-2	SPOOL HOLDER, 2	
54-10	S02786002	1	スレッドハンガーアッセンブリ2	THREAD HANGER ASSY, 2	
54-10-1	S02787002	1	スレッドハンガー-2	THREAD HANGER, 2	
54-10-2	150183000	2	スレッドハンガーベース	THREAD HANGER BASE	
54-10-3	142990001	2	スレッドブッシュ	THREAD BUSH	
54-11	150172003	1	コラムパイプ	COLUMN PIPE	
54-12	S40641001	1	スプールシャフトネジセットA	SPOOL SHAFT & SCREW SET, A	
54-12-1	021500106	4	ナットM5	NUT, 1 M5	
54-12-2	062501406	1	ナットM5X14	SCREW, PAN M5X14	
54-12-3	062501406	1	ナットM5X14	SCREW, PAN M5X14	
54-12-4	062501406	2	ナットM5X14	SCREW, PAN M5X14	
54-12-5	026050136	2	ワッシャー、平型S5	WASHER, PLAIN S 5	

118-H80-910

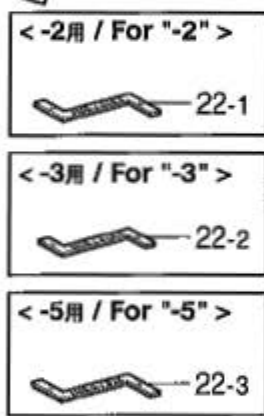
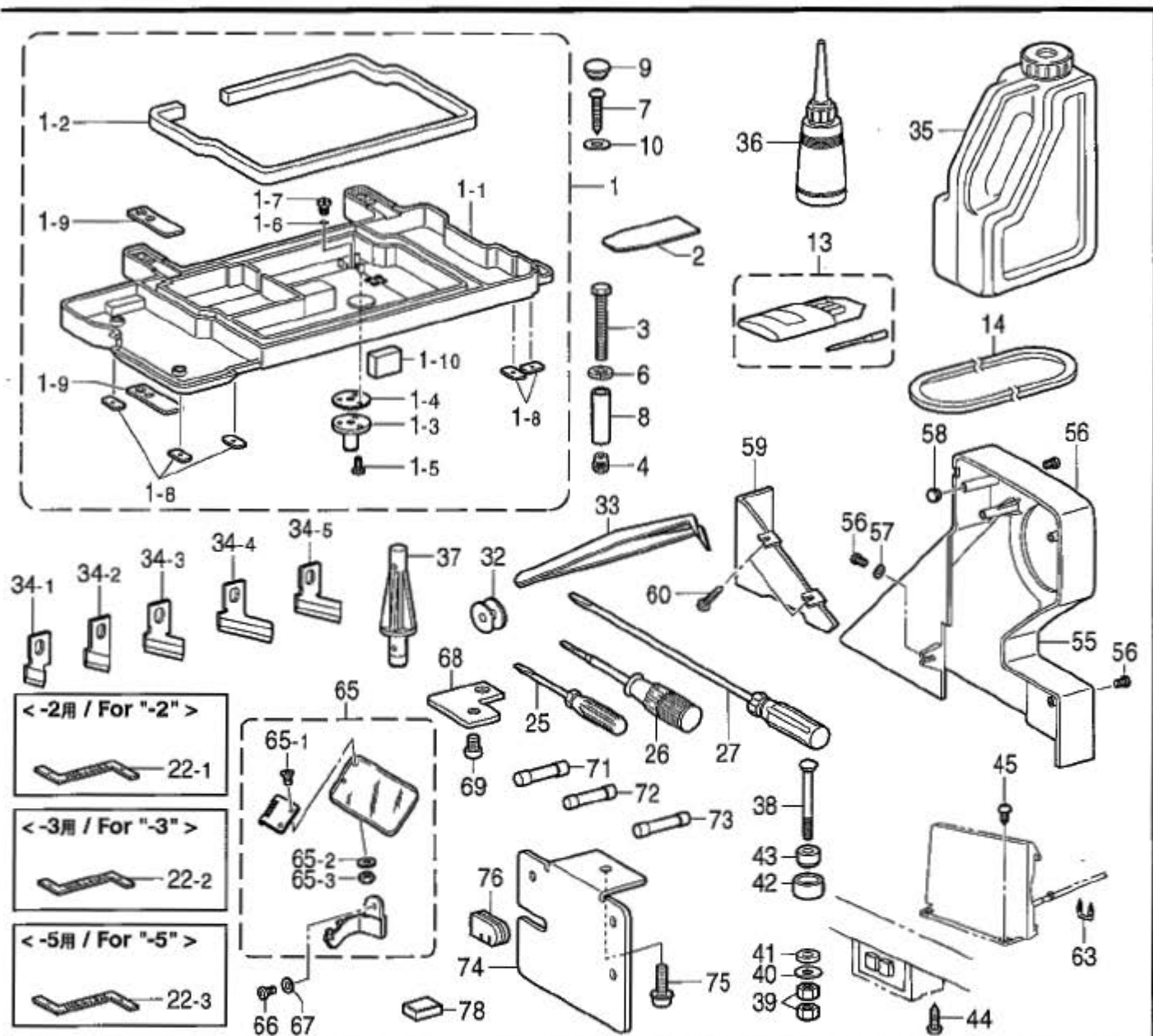

" オプション部品 / OPTION PARTS "

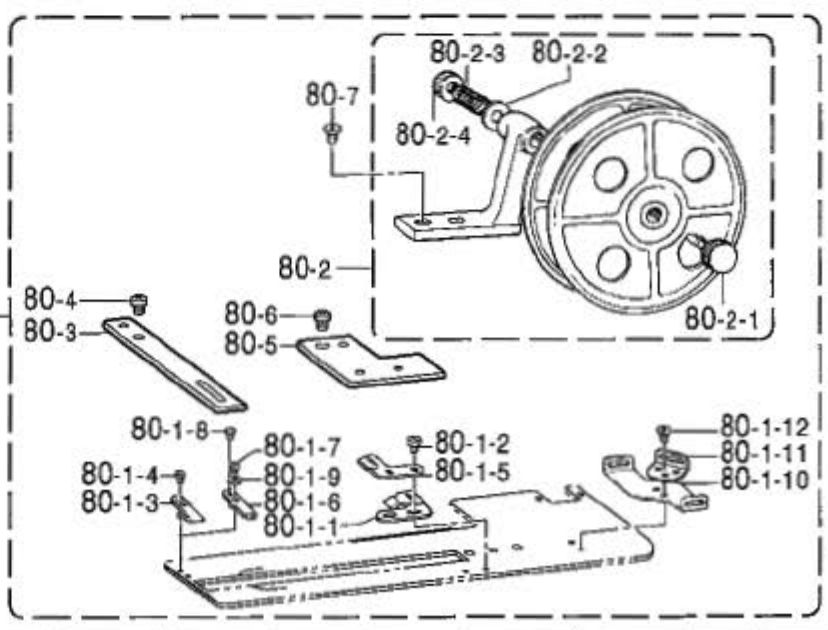
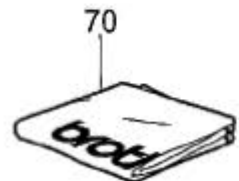

Z2. 付属品関係 / Accessories

REF.NO	CODE	QTY	ヒンメイ	NAME OF PARTS	RM
1	S50330101	1	ベッドベース	BED BASE ASSY	
1-1	S50331000	1	ベッドベース	BED BASE	
1-2	S50332000	1	オイルパッキング	OIL PACKING	
1-3	S54768001	1	排水プレート	DRAIN PLATE	
1-4	S50334000	1	パッキング	PACKING	
1-5	037401415	3	タップスクリュー、パンV M4X14	TAPPING SCREW, PAN V M4X14	
1-6	081007070	1	Oリング P7	O RING, P7	
1-7	140518001	1	ネジ SM7.94	SCREW, SM7.94X10	
1-8	S50335000	5	ベッドベースクッションA	BED BASE CUSHION, A	
1-9	S50336000	4	ベッドベースクッションB	BED BASE CUSHION, B	
1-10	S50337000	2	ベッドベースクッションC	BED BASE CUSHION, C	
2	S50338000	1	オイルストッププレート	OIL STOPPER PLATE	
			<ベッド台取付用>	<For setting the bed base assy>	
3	S24250001	4	ボルト M8X90	BOLT, M8X90	
4	S50342000	4	ナット、フランジ M8	NUT, FLANGE M8	
6	028080246	4	ワッシャー、スプリング 2-8	WASHER, SPRING 2-8	
7	101118001	3	丸頭ネジ 4.5X20	WOOD SCREW, ROUND M4.5X20	
8	S50339001	4	ベッドベースカラー	COLLAR	
9	104449001	2	ゴムキャップ 15.5	RUBBER CAP, 15.5	
10	025050236	3	ワッシャー、平 M 5	WASHER, PLAIN M 5	
			<国内-2,-3用>	<For "-2 & -3">	
13	S50180475	1	ミシン針 134クミ <#11 NM75>	NEEDLE ASSY, NM75..... <#11 NM75>	
			<輸出-2,-5用>	<For "-2 & -5">	
13	S50180490	1	ミシン針 134クミ <#14 NM90>	NEEDLE ASSY, NM90..... <#14 NM90>	
14	S18707153	1	Vベルト M30	BELT, VM WHITE	
			<-2用>	<For "-2">	
22-1	S13595101	1	テーパーゲージ -2	GAUGE, -2	
			<-3用>	<For "-3">	
22-2	S13596101	1	テーパーゲージ -3	GAUGE, -3	
			<-5用>	<For "-5">	
22-3	S13597101	1	テーパーゲージ -5/BAS	GAUGE, -5/BAS	
25	142443001	1	ネジ マシン 1.9X52	SCREW DRIVER, 1.9X52	
26	118837001	1	ネジ マシン 3.4X70	SCREW DRIVER, 3.4X70	
27	101572101	1	ネジ マシン 5.5X190	SCREW DRIVER, 5.5X190	
32	159158051	1	ボビン	BOBBIN	
33	117466000	1	ピンセット	PINCETTE	
34-1	S51290001	1	カッタ 3/8	CUTTER, 3/8	
34-2	S51354001	1	カッタ 5/8	CUTTER, 5/8	
34-3	S51358001	1	カッタ 1	CUTTER, 1	
34-4	S51360001	1	カッタ 32	CUTTER, 32	
34-5	S51359001	1	カッタ 29	CUTTER, 29	
35	S55663001	1	オイルタンク	OIL TANK ASSY	
36	114483002	1	オイルライナー	OILER ASSY	
37	159384009	1	ヘッドレスト	HEAD REST	
			<コントロールボックス取付用>	<For setting the Control box>	
38	133740006	4	六角ボルト M6X70	BOLT, SQUARE M6X70	
39	021060106	8	ナット 1 M6	NUT, 1 M6	
40	025060336	4	ワッシャー、平 L 6	WASHER, PLAIN L 6	
41	S00617000	4	ゴムリングカラー	RUBBER COLLAR	
42	146256001	4	クッションカラー	CUSHION COLLAR	
43	146255000	4	クッション	CUSHION	

118-H80-910

付属品の明細は変更することがあります。

The details of included accessories are subject to change.

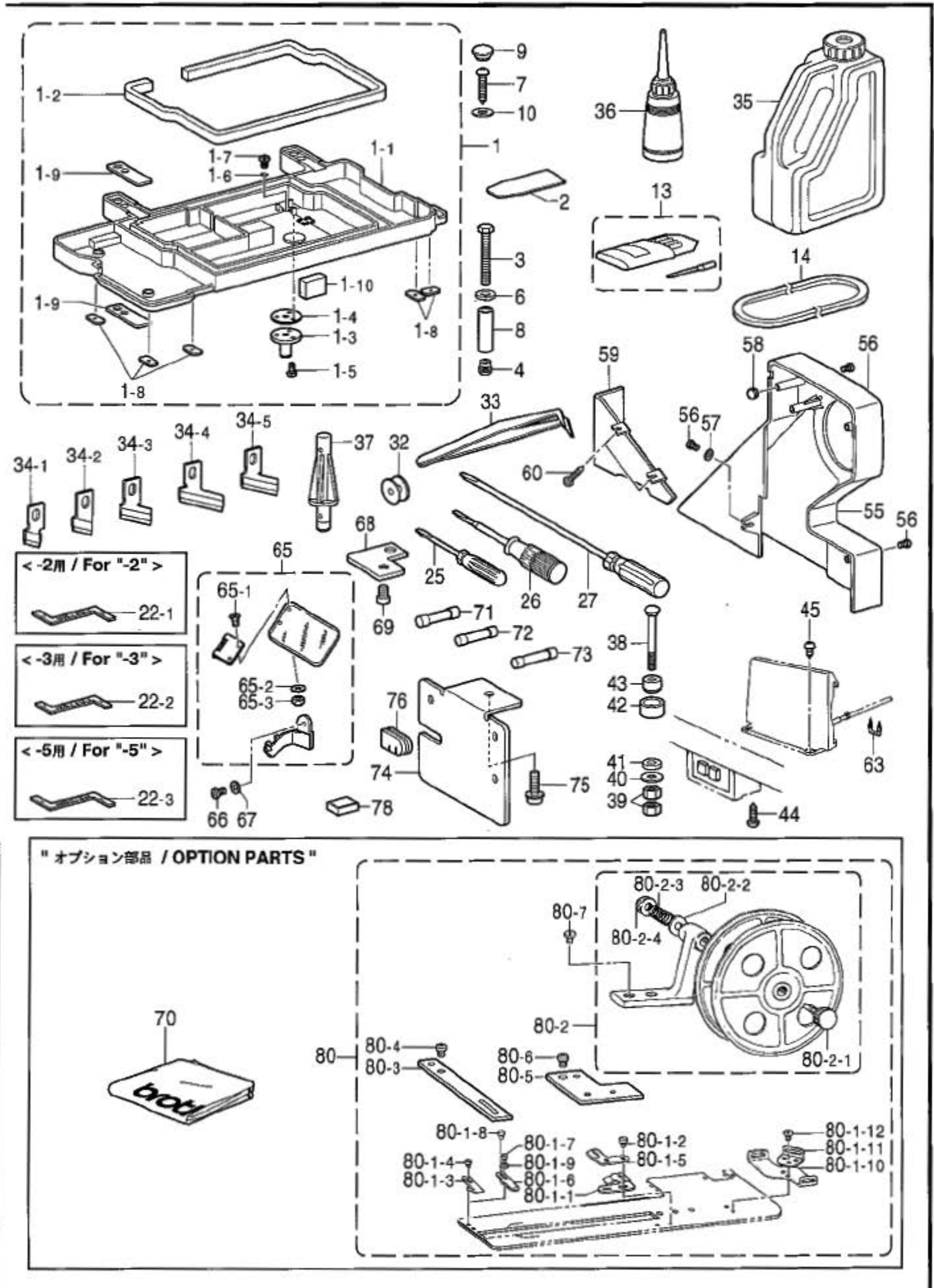

Z2. 付属品関係 / Accessories

REF.NO	CODE	QTY	ヒンメイ	NAME OF PARTS	RM
44	032461606	2	<電源スイッチ取付用> +丸モクネジ 4.5X16	<For setting the Power supply switch> WOOD SCREW, ROUND M4.5X16	
45	032422505	4	<操作パネル取付用> +丸モクネジ 4.1X25	<For setting the Opreation panel> WOOD SCREW, ROUND M4.1X25	
55	S50343000	1	ベルトカバー	BELT COVER	
56	062401006	3	ナベコ4X10	SCREW, PAN M4X10	
57	025040236	1	ヒラサカネチユウ4	WASHER, PLAIN M 4	
58	104450101	2	ゴムセン8	RUBBER CAP, 8	
59	S50344001	1	ベルトカバーイタ	PLATE, BELT COVER	
60	032461606	2	+丸モクネジ 4.5X16	WOOD SCREW, ROUND M4.5X16	
63	200190001	6	ステツブル	STAPLE	
65	S37111001	1	アイガードクミ	EYE GUARD ASSY	
65-1	S01700001	2	丸サラネジ 3.18X7	SCREW, FLAT SM3.18X7	
65-2	025030232	2	ヒラサカネチユウ3	WASHER, PLAIN M 3	
65-3	021660102	2	ナット1.8X3.18	NUT, 1 SM3.18	
66	062710612	1	ナベコ4.76-32X6	SCREW, PAN SM4.76-32X6	
67	148847001	1	ザガネ	WASHER, PLAIN 4.76	
68	S50345001	1	アイガードサエイタ	EYE GUARD SUPPORT	
69	062680812	1	ナベコ4.37-40X8	SCREW, PAN SM4.37-40X8	
71	218469001	2	ガレユース 15A#2	FUSE	
72	S08030000	1	ガレユース 5AFB	FUSE, 5A :FB	
73	153242000	2	ヒユース 6A	FUSE, 6A	
74	J03411001	1	EZフミミトリツケイタ	SETTING PLATE, EZ-TREADLE	
75	J00353001	3	+ナベコ5X14DB	SCREW, PAN (S/P WASHER) M5X14	
76	J02036001	1	テトコトフツシンクV	BUSHING, V CORD	
78	112525000	1	シユウジンマグネット	MAGNET	
			"オプション部品"	"OPTION PARTS"	
70	144226001	1	トウフカバー	HEAD COVER	
80	S50346001	1	テープオサエウインダクミ	TAPE GUARD WINDER ASSY	
80-1	S51896001	1	テープオサエクミ	TAPE GUARD ASSY	
80-1-1	144998001	1	テープオサEB	TAPE GUARD, B	
80-1-2	105288002	2	シメネジ 2.38	SCREW, SM2.38	
80-1-3	144997001	1	テープオサEA	TAPE GUARD, F	
80-1-4	122771051	2	シメネジ 2.38	SCREW, SM2.38	
80-1-5	144999001	1	テープオサEC	TAPE GUIDE, C	
80-1-6	144628001	1	テープオサEF	TAPE GUARD, F	
80-1-7	122771051	1	シメネジ 2.38	SCREW, SM2.38	
80-1-8	105970001	1	シメネジ 2.38	SCREW, SM2.38	
80-1-9	110067001	1	カラ	COLLAR	
80-1-10	143749001	1	テープアンナイシタ	TAPE GUIDE, LOWER	
80-1-11	143748001	1	テープアンナイウエ	TAPE GUIDE, UPPER	
80-1-12	062660412	2	ナベコ3.18-40X4	SCREW, PAN SM3.18-40X4	
80-2	143767102	1	テープウインダクミ	TAPE WINDER ASSY	
80-2-1	143980001	1	ツマミネジ	SCREW	
80-2-2	108494001	1	ザガネ	WASHER	
80-2-3	108495001	1	テープウインダクミバネ	SPRING, COMPRESSION	
80-2-4	100136001	1	イトチヨウシナツト	NUT, TENSION	
80-3	S50348001	1	テープアンナイウエ	TAPE GUIDE, U	
80-4	062400812	1	ナベコ4X8	SCREW, PAN M4X8	
80-5	S50349001	1	テープウインダクミツケイタ	TAPE WINDER SETTING PLATE	
80-6	062400812	1	ナベコ4X8	SCREW, PAN M4X8	
80-7	107407003	2	シメネジ 4.37	SCREW, SM4.37X9	

118-H80-910

付属品の明細は変更することがあります。

The details of included accessories are subject to change.

Z3 . 付属品関係 (オプション部品) / Accessories (Option parts)

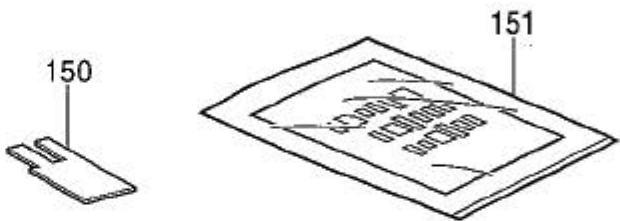
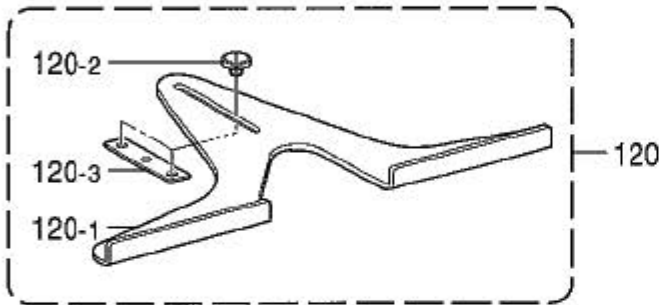
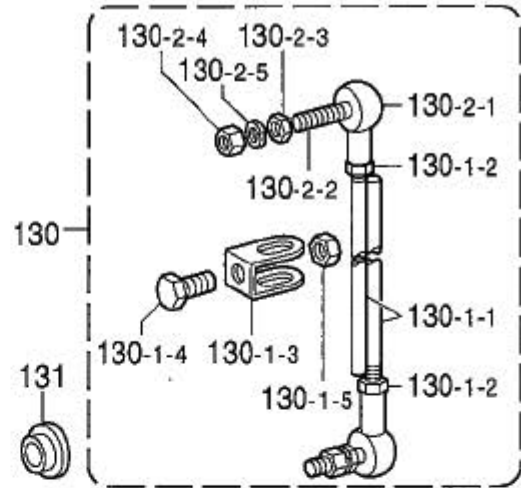
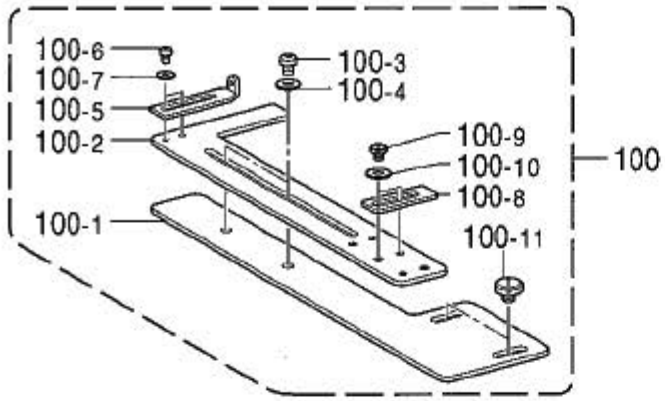

118-H80-910

Z3. 付属品関係 (オプションパーツ)/ Accessories (Option parts)

REF.NO	CODE	QTY	ヒンメイ	NAME OF PARTS	RM
100	S50477001	1	ジヨウキクミ	RULER ASSY	
100-1	S06139001	1	ジヨウキA	RULER, A	
100-2	S06140001	1	ジヨウキB	RULER, B	
100-3	062680512	2	ナコ437-40X5	SCREW, PAN SM4.37-40X5	
100-4	025680232	2	ヒラサガネチヨウ4.37	WASHER, PLAIN M 4.37	
100-5	146000001	1	ハサミササエ	THREAD TRIMMER SUPPORT	
100-6	062670412	2	ナコ357-40X4	SCREW, PAN SM3.57-40X4	
100-7	105161003	2	ザカネ	WASHER	
100-8	141620001	1	ホウシイタハランス	BALANCER	
100-9	101671002	2	シメネジ4.37	SCREW, SM4.37	
100-10	025680132	2	ヒラサガネチヨウ4.37	WASHER, PLAIN S 4.37	
100-11	S36522001	2	シメネジ4.37	SCREW, SM4.37	
120	S50350001	1	ジヨウキクミ800E	RULER ASSY, 800E	
120-1	S50476001	1	ヨコジヨウキ	RULER	
120-2	S36522001	2	シメネジ4.37	SCREW, SM4.37	
120-3	S50351001	1	ヨコジヨウキスハ-サ-	RULER SPACER	
130	133797101	1	レンゲツカンクミ	CONNECTING ROD ASSY, L=210	
130-1	119710001	1	レンカンクミ	CONNECTING ROD ASSY	
130-1-1	119711001	2	レンカン	CONNECTING ROD	
130-1-2	021060106	2	1シユナツト6	NUT, 1 M6	
130-1-3	119101001	1	レンカンタキ	CONNECTING ROD CLAMP	
130-1-4	017841606	1	6カクホルト7.94-18	BOLT, SM7.94-18	
130-1-5	133643006	1	6カクナツト7.94-18	NUT, SM7.94-18	
130-2	133792101	2	シヨイントクミ	JOINT ASSY	
130-2-1	133793001	2	スタツト	STUD	
130-2-2	133794001	2	ホントイ	BODY	
130-2-3	133795001	2	リング	RING	
130-2-4	021060106	2	1シユナツト6	NUT, 1 M6	
130-2-5	028060243	2	ハネサカネ2-6	WASHER, SPRING 2-6	
131	114859001	1	レンカンカラー	COLLAR	
150	S54767000	1	ホシヨシト	SHEET	
151	S55361100		ハネラハルフクロイリ	LABEL SET	

118-H80-910









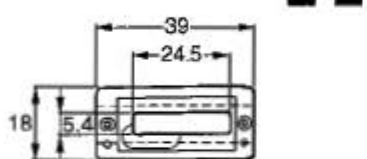
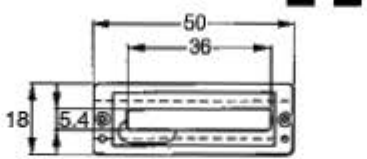
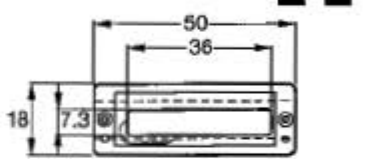

Ga1 . ゲージ部品一覧表 / Gauge parts List

カッター / Cutter

<p>S51117-001</p> <p>1/4</p>	<p>S51290-001</p> <p>3/8</p>	<p>S51351-001</p> <p>7/16</p>	<p>S51352-001</p> <p>1/2</p>	<p>S51353-001</p> <p>9/16</p>	<p>S51354-001</p> <p>5/8</p>
<p>S51355-001</p> <p>11/16</p>	<p>S51356-001</p> <p>3/4</p>	<p>S25642-001</p> <p>13/16</p>	<p>S51357-001</p> <p>7/8</p>	<p>S51358-001</p> <p>1</p>	
<p>S51359-001</p> <p>29</p>	<p>S51360-001</p> <p>32</p>	<p>147987-001</p> <p>45</p>			
<p>147941-001</p> <p>48</p>	<p>147233-001</p> <p>50</p>	<p>S01271-001</p> <p>3/8</p>	<p>S01272-001</p> <p>7/16</p>		
<p>S01273-001</p> <p>1/2</p>	<p>S03280-001</p> <p>9/16</p>	<p>S01274-001</p> <p>5/8</p>	<p>S01275-001</p> <p>3/4</p>	<p>S01276-001</p> <p>7/8</p>	<p>S35630-001</p> <p>1</p>

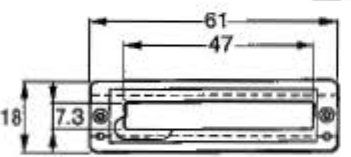
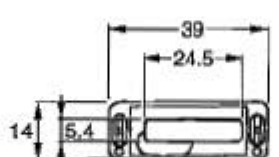
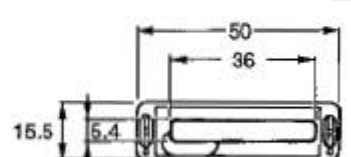
Ga2 . ゲージ部品一覧表 / Gauge parts List

- ※ 1 布つかみ組フィンガーガード付 / Work clamp assy, W/F-G
- ※ 2 布つかみ組 / Work clamp assy
- ※ 3 フィンガーガード / Finger guard
- ※ 4 布つかみ / Work clamp

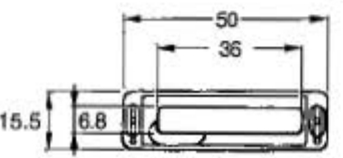
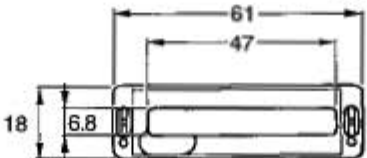
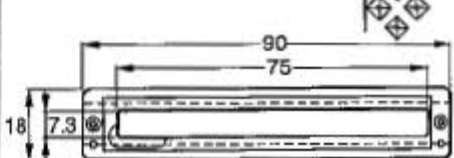
< -2用 / For "-2" >		
※ 1 S37101-102 (16mmRS)	※ 1 S37100-102 (25mmRS)	※ 1 S55347-002 (25mmRSW)
※ 2 159764-202 (16mmRS)	※ 2 159765-202 (25mmRS)	※ 2 S55346-002 (25mmRSW)
※ 3 159079-000	※ 3 159080-000	※ 3 159080-000
※ 4 159761-002	※ 4 159762-002	※ 4 S55345-002
※ 3 	※ 3 	※ 3 
※ 4  縫製エリア 4 X 20	※ 4  縫製エリア 4 X 32	※ 4  縫製エリア 6 X 32
< -2用 / For "-2" >	< -3用 / For "-3" >	
※ 1 S37109-102 (32mmRS)	※ 1 S37103-101 (16mm)	※ 1 S37102-101 (25mm)
※ 2 159766-202 (32mmRS)	※ 2 S01466-201 (16mm)	※ 2 S01467-201 (25mm)
※ 3 159081-000	※ 3 159079-000	※ 3 159080-000
※ 4 159763-002	※ 4 145136-001	※ 4 144630-001
※ 3 	※ 3 	※ 3 
※ 4  縫製エリア 6 X 40	※ 4  縫製エリア 4 X 20	※ 4  縫製エリア 4 X 32
< -3用 / For "-3" >		< -5用 / For "-5" >
※ 1 S55350-001 (25mmW)	※ 1 S37110-101 (32mm)	※ 1 S54518-101
※ 2 S55349-001 (25mmW)	※ 2 S01468-201 (32mm)	※ 2 S51514-101
※ 3 159080-000	※ 3 159081-000	※ 3 S54517-000
※ 4 S55348-001	※ 4 144632-001	※ 4 S54515-001
※ 3 	※ 3 	※ 3 
※ 4  縫製エリア 5.4 X 32	※ 4  縫製エリア 5.4 X 40	※ 4  縫製エリア 6 X 70







針板 / Needle plate

< -2用 / For "-2" >		
S50663-001 (1.2mmS)	S50664-001 (1.4mmS)	S50665-001 (1.6mmS)
< -3用 / For "-3" >		
S51248-101 (1.2mm)	S51249-101 (1.4mm)	S51250-101 (1.6mm)

平カッター用 / For "flat cutter"

< -5用 / For "-5" >	< -2用 / For "-2" >	
S55344-001 (1.2mm)	針板 / Needle plate S50321-001 (1.2mmS)	カッターウケ / Plastic plate 151843-001
S54522-001 (1.4mm)	< -3用 / For "-3" >	
S54522-001 (1.4mm)	針板 / Needle plate S50322-101 (1.2mm)	カッターウケ / Plastic plate 156612-001

Wa. 警告ラベル / Warning labels

警告ラベル / Warning labels	品名 / Name of parts	Size(mm)	Code
	電撃ラベル・和	40 × 64	S38353-101
	Label, etc. shock 4 lang.	35 × 118	S38352-101
	操作注意ラベル・和	40 × 64	S38350-001
	Label, operation Eng.	40 × 64	S38349-001
	ワーニングマーク Mark, injury	L=16 R=0.8	S36924-001
	PE マーク Mark, grounding	7.5 × 12.5	S37059-001
	アースマーク Mark, grounding	φ 12	S37060-001

索引 / INDEX

CODE	REF.NO	Page	CODE	REF.NO	Page	CODE	REF.NO	Page	CODE	REF.NO	Page
002300603	83	28	018061622	34	38	025060132	40	10	037300615	11-1-13	64
	29	58		36	38	025060232	14	6	037301015	11-1-6	64
002301003	1-1-13	44	018102536	12-4	6		3	14	037401015	102-4	48
002401006	13	66	018300636	19	30		2	22	037401415	1-5	70
008400604	1-21	46	018300836	24-3	36	025060236	50-1-9	50	047200642	23	34
012400636	4	34	018400822	9	10		50-2-9	52	048030342	1-5	40
	25	34	018401022	4	14		51-1-9	52	048040342	26	34
012500536	26	14	018401222	5	8		51-2-9	54		33-4	38
013761410	25	4		15	10		51-3-9	54	048060142	41	10
014060632	5-2	14	018401236	1-26	47		51-4-9	56		35-8	38
	6-2	14	018501022	33	20	025060336	40	70	048060342	15	2
014400432	1-3	30	018501236	1-9	46	025080132	14	2		26	10
014500632	1-11	66	018502022	48	16		25	10		26	20
014680622	22-3	20	018680522	27-1-5	14		7	34		71	32
	33-5	38		27-2-5	18	025100236	6	66		8	34
014760622	16	2	018680632	15	20	025350132	6	26	048080342	4	40
	20	2	018680822	12	14		52	26	048150142	1-2	6
	8	4		40	14		15	58	048220242	19	6
	11	4		53	18		22	58	048300242	12-6	6
	13	4		5-5	62	025350332	3	22	060300612	6	8
	9	6		10-4	64	025680132	24	14	060630312	30-5	40
	20	6	018681022	27-1-4	14		41	14	060660416	21	14
	8	8		34	14		16-4	36	060670412	31	40
	10	8		27-2-4	18		35-4	38	060670512	49	12
	13	8		13	20		35-12	38		7-3	30
	11	10		35-3	38		7	44		65	32
	14	10		35-11	38		100-10	74		67	32
	22	10	018681232	17	14	025680232	18	36	060670612	4	22
	27	10		29	20		26	36		16	26
	29-4	10	021040105	30-1-8	50		100-4	74		21	26
	44	10		30-2-8	50	025680234	14	30		78	28
	15	14		30-3-8	50	026040236	17	34	062060806	54-2-1	68
	2	20	021060106	39	70	026050136	54-12-5	68	062300502	20	30
	24	20		130-1-2	74	028030246	24-5	36	062300806	1-2	44
	7	22		130-2-4	74		1-26	60		8	58
	2-2	22	021080202	37	20	028040245	10	66		10	58
	2-1-3	24	021100206	5	66	028050242	16-1-5	10		12	58
	2	30	021100302	12-5	6		35-6	38		17	58
	6	30	021300206	24-6	36	028050246	1-8	46		25	58
	2-2	36		1-1-14	44		54-8-2	68	062400612	11	22
	5	40		1-25	60	028060243	130-2-5	74		13	22
	12	40	021400106	903	58	028060246	50-1-10	50		68	28
014770622	3	4		906	58		50-2-10	52		71	28
	7	4	021500106	54-8-3	68		51-1-10	52	062400616	22	34
	5	10		54-12-1	68		51-2-10	54	062400806	2	8
	21-2	20	021500312	35-7	38		51-3-10	54		2	44
	4-2	22	021660102	65-3	72		51-4-10	56	062400812	80-4	72
014780622	6-2	6	021670202	55	42	028080242	36	20		80-6	72
	10-3	6	021680202	19	2	028080246	6	70	062400816	14	34
	4-3	20		16-3	36	028100246	1-14	66		16	34
	28	34	021710202	24	4		7	66	062401006	56	72
017841606	130-1-4	74	021910302	11	20	028680242	35	14	062401063	9	66
018060831	50-1-8	50	025030136	1-27	60		27	36	062500802	50-1-5	50
	50-2-8	52	025030232	65-2	72	031351006	5-3	62		50-2-5	50
	51-1-8	52	025040132	30-4	40	031452206	54-2-2	68		51-1-5	52
	51-2-8	54		34	40	032422003	5-6	62		51-2-5	54
	51-3-8	54	025040173	11	66		11-3	64		51-3-5	54
	51-4-8	56	025040232	52	12	032422505	45	72		51-4-5	56
018061022	13	6	025040236	57	72	032461606	44	72	062501406	54-12-2	68
	2	10	025050236	1-7	46		60	72		54-12-3	68
018061622	16	8		10	70	037200615	11-1-10	64		54-12-4	68

CODE	REF.NO	Page	CODE	REF.NO	Page	CODE	REF.NO	Page	CODE	REF.NO	Page
062670412	100-6	74	0A4400605	59	56	105237002	59	42	122771051	80-1-4	72
062670512	12	26	0A4400606	50-1-12	50	105288002	80-1-2	72		80-1-7	72
	58	26		50-2-12	52	105970001	41	40	123185001	39-6	40
	66	28		51-1-12	52		80-1-8	72	133643006	130-1-5	74
	81	28		51-2-12	54	106436001	53	26	133740006	38	70
	6-8	36		51-3-12	54	106629002	43	40	133792101	130-2	74
	7-8	36		51-4-12	56	107093002	25	36	133793001	130-2-1	74
062670612	7	22	0A4400805	1-1-6	44	107149001	54	26	133794001	130-2-2	74
	5	26		30-1-7	50	107401001	46-1-3	14	133795001	130-2-3	74
	28	26		30-2-7	50		46-5-4	18	133797101	130	74
	51	26	0A4401205	30-3-7	50		10-12-3	64	140004001	5-2-1	4
	17	30	0A5302005	19	58	107404001	46-1-4	16	140407001	35	10
	30	30	0A5400805	1-23-4	47		46-3-4	16	140430001	5-4	4
	21	58	0A5400806	27	58		46-5-5	18	140518001	1-7	70
062670712	6-5	36	0A5401006	1-34	47		10-12-4	64	140553102	16	4
	7-5	36		1-36	47	107407003	80-7	72	141208001	31	10
062670812	14	58		1-37	47	107639001	52-2	42	141513001	22-3	36
062671212	39	10		52	58	107744001	1-2	40	141514001	22-4	36
062671612	54	42		54	58	108265009	24-3	34		33	40
062680512	17-2	40		56	58	108494001	80-2-2	72		39-5	40
	56	42		59	58	108495001	80-2-3	72	141519001	1-3	40
	100-3	74	0A5401206	902	58	110027001	2-1	36	141590001	27	30
062680612	5	2		905	58	110067001	80-1-9	72	141619001	6-1	22
	43	14	0A5403005	1-5	46	110161004	16-1-4	10	141620001	6-2	22
	58	18	0A5501005	101	48		1-4	40		100-8	74
	14	26	0B1351606	11-4	64	110167001	39-2	40	142274101	5-3	22
	34	26	100022005	26	4	110168001	39-3	40	142443001	25	70
	64	28	100136001	80-2-4	72	110215002	29	40	142990001	54-10-3	68
	11	30	100242003	46	10		38	40	143748001	80-1-11	72
	17	36	100250001	2	4	110367001	4	4	143749001	80-1-10	72
	10-8	64	100402004	51-3	32		13	10	143767102	80-2	72
062680712	31	26	100644005	5	24		27	20	143980001	80-2-1	72
062680812	23	14		23	36	110494001	3	40	144103009	31-4	30
	9	26	100645003	7-4	30	110735002	27-1-6	14		40-4	30
	69	72		10	30		27-2-6	18	144110001	31-5	30
062681012	27	4	101118001	7	70	111466101	30	10	144226001	70	72
062681412	6	44	101572101	27	70	111865001	21	6	144628001	80-1-6	72
062710612	66	72	101671002	6-3	22	112467002	7	26	144630001	46-3-1	16
062710812	39	20		100-9	74	112525000	78	72			76
062711012	3	2	102538002	51	12	112751003	70	32	144632001		76
	7	2	102630001	6	20	113316001	66	32	144707001	46-3-3	16
062711212	3	8	104449001	27	2	113730001	20	40	144872101	10	26
062711412	32	20		32	2	114483002	36	70	144874001	11	26
062711612	9	2		33	2	114859001	131	74	144875001	1	26
	4	8		39	2	114988001	49	30	144997001	80-1-3	72
062761012	2	14		56	2	115188001	24-2	34	144998001	80-1-1	72
	8	20		9	70	115503001	20	20	144999001	80-1-5	72
070608800	18	6	104450101	11	2	117143003	17	2	145136001		76
070688850	10	14		29	2	117160001	33-3-3	18	145371001	37	40
072630260	1-3	6		30	2		10-2-3	64	145440001	40-1	30
076002450	2-1	22		31	2	117363001	16-4	10	145446001	31-2	30
076200800	12-7	6		34	2		19	10		40-2	30
076202801	1-3	66		35	2	117466000	33	70		51-6	32
081005070	4	30		36	2	117934001	25	2		24-1	34
081007070	1-6	70		37	2	117936001	59	2	145465001	5-1	4
081012070	32	36		38	2	118735001	15	8	145472001	36	10
081014870	51-4	32		58	72	118837001	26	70	145478101	23-3	10
087310815	1-1-5	44	104451101	28	2	119101001	130-1-3	74		28	10
087311015	1-1-10	44	104521001	4-1	22	119710001	130-1	74		29-3	10
0A4301005	1-24	60	105130001	37	14	119711001	130-1-1	74		10-3	40
0A4400605	58	56	105161003	100-7	74	120263001	58	2	145519001	51-5	32

CODE	REF.NO	Page	CODE	REF.NO	Page	CODE	REF.NO	Page	CODE	REF.NO	Page
146000001	100-5	74	159221001	51-8	32	228475000	10-18	64	S00480000	50	26
146255000	43	70	159224001	63	32	229017001	1-23-7	47		20	58
146256001	42	70	159267001	2	40		104	48	S00554000	1-22	46
147233001	50	75	159269001	16	40		1-20	66	S00617000	41	70
147941001	48	75	159272001	21	40		14	66	S00712101	27	40
147987001	45	75	159343001	16-2	36	232384001	1-24-2	47	S00901001	23	40
148847001	67	72	159379001	22-4	20	414900001	56-1-4	56	S00902001	16-3	10
149127001	18	40		61	42	552907000	4	26		18	10
	40	40		64	42		51	58		24	40
149809000	13	64	159384009	37	70	552908000	53	58	S00903001	22	40
150172003	54-11	68	159624001	9-2	4		55	58	S01271001	3/8	75
150173003	54-7	68	159625001	18-2	8	625010000	13	58	S01272001	7/16	75
150174000	54-6-1	68	159761002		76	J00107001	2	66	S01273001	1/2	75
150179002	54-8-1	68	159762002	46-1-1	14	J00351001	10	68	S01274001	5/8	75
150182000	54-4	68			76	J00353001	75	72	S01275001	3/4	75
150183000	54-10-2	68	159763002		76	J00494001	2	68	S01276001	7/8	75
150189109	54-1	68	159764202		76	J00649001	102-1-2	48	S01466201		76
150382001	19	4	159765202	46-1	14	J01684001	1-23-1-12	46	S01467201	46-3	16
150491101	11	40			76	J01935001	102-1-1	48			76
150553003	28	30	159766202		76	J02036001	76	72	S01468201		76
151843001		77	159805001	31-3	30	J02130001	102-3	48	S01696001	49	40
151927001	55	26		40-3	30	J02278001	1-12	66	S01700001	65-1	72
152969001	28	58		51-7	32	J02293001	8	68	S01998001	51	42
153057102	17	20	159917201	69	32	J02343001	1-23-8	47	S02460001	19	14
153242000	1-24-5	47	159924001	53	42	J02441001	1-23-1-7	46	S02563001	14	36
	73	72	159926001	46-1-2	14	J02443001	1-23-1-1	46		15	36
153483001	23	4		46-3-2	16	J02449001	1-23-1-15	46	S02761309	54	68
154965001	21	4		46-5-3	18	J02493001	1-15	66	S02773001	54-2	68
155578000	47	12		10-12-2	64	J02513001	1	68	S02778002	54-9	68
156612001		77	159927001	46-1-5	16	J02515001	3	68	S02786002	54-10	68
157968001	21	34		46-3-5	16	J02516001	6	68	S02787002	54-10-1	68
158830001	21	2	180721001	20-2-2	24	J02517001	3	66	S03280001	9/16	75
158831001	22	2	183507001	20-2-3	24	J02525001	1-10	66	S06139001	100-1	74
158832000	23	2	183526001	20-1-1	24	J02537001	1-8	66	S06140001	100-2	74
158879001	12	2	183598001	20-1-3	24	J02621001	1-19	60	S07478000	8	24
158885201	15-1	4	183827001	4	22	J02657001	30-1-3	50	S08030000	1-24-4	47
158888001	10	4	200190001	63	72		30-2-3	50		72	72
158893000	5	6	203684001	1-7	66		30-3-3	50	S08047000	1-1	60
158945001	19	8	216205000	1-13	66		30-4-3	54	S09142000	1-11	46
158946001	20	8	217071001	5	68	J02727001	1-23-1-13	46	S09212001	21-1	20
159078001	44	14	218469001	1-23-1-11	46	J02989001	1-17	66	S09477001	20-2-1	24
159079000		76		71	72	J02990001	1-19	66	S10174000	18	34
		76	218859001	30-1-5	50	J02991001	1-18	66	S10243000	26	58
159080000	47-1	16		30-2-5	50	J03275001	4	66	S10820000	8	47
		76		30-3-5	50	J03283001	1-23-1-9	46		50-1-11	50
		76		30-4-5	54	J03284001	1-23-1-2	46	S10820001	9	47
		76		31	58	J03285001	1-23-1-3	46	S10820002	10	47
		76	221419001	1-23-1-23	46	J03291001	1-23-1-24	46		50-2-11	52
159081000		76	224508001	4	68	J03296001	1-23-1-21	46	S10820003	11	47
		76		7	68	J03324001	1-23-1-5	46	S10820004	12	47
159104001	22-2	20		9	68	J03410001	8	66	S10820005	13	47
159113001	60	42		11	68	J03411001	74	72		51-1-11	52
159117001	9	20	224514001	30-1-4	50	J03417001	103	48	S10820006	14	47
159145001	5	22		30-2-4	50	J03419001	102-1	48		51-2-11	54
159150000	24	2		30-3-4	50	J03457001	1-16	66	S10820007	15	47
	26	2		30-4-4	54	J80081040	2	62		51-4-11	56
159158051	22	24	228475000	49	26	J80380040	4	62	S10820008	16	47
	32	70		76	28	J80813001	102-2	48		51-3-11	54
159187000	29	26		32	47	J80814001	102	48	S12004000	18	14
159193000	37	26		6	58	J80863001	1	66	S12441001	40-7	30
159219101	31-1	30		30	58	S00306001	13	2	S13595101	22-1	70

CODE	REF.NO	Page	CODE	REF.NO	Page	CODE	REF.NO	Page	CODE	REF.NO	Page
S13596101	22-2	70	S37110101		76	S43178000	1-18	60	S49496001	1-1-4	44
S13597101	10-19	64	S37111001	65	72	S43186000	1-10	46	S50110001	6-1	14
	22-3	70	S37927000	45	10		5	47	S50111000	11	24
S13650001	5-4	62	S37940001	2	8	S43250100	11-1-1	64	S50113101	22-2	36
S18707153	14	70	S38082001	5	44	S43251000	11-1-2	64	S50120001	7	20
S19817001	5	36	S38118000	30-3-2	50	S43252000	11-1-3	64	S50124001	2	2
S20345001	4	47	S38128000	51-1-7-1	52	S43253000	11-1-4	64	S50125001	4	2
S21755001	2	36		51-2-7-1	54	S43255000	11-1-7	64	S50126001	6	2
S21798001	54-8	68		51-3-7-1	54	S43256000	11-1-8	64	S50127001	8	2
S23337001	3	36		51-4-7-1	56	S43257000	11-1-9	64	S50128001	10	2
S23618001	50-1-6	50	S38133000	30-1-2	50	S43267000	11-1-14	64	S50131001	55	2
	50-2-6	50		30-4-2	54	S43268000	11-1-15	64	S50132000	1	4
	51-1-6	52	S38145000	57	58	S43270000	11-1-16	64	S50133001	5	4
	51-2-6	54	S38146000	31	47	S43271000	11-1-11	64	S50136001	5-2	4
	51-3-6	54		53	48	S43272000	11-1-12	64	S50142000	5-5	4
	51-4-6	56	S38155000	1-25-1	47	S43275000	1-12	46	S50143001	9	4
S24250001	3	70		1-6	60	S43276000	1-13	46	S50144001	9-1	4
S25328001	59	26	S38200000	1-24-1	47	S43318000	1-15	46	S50146001	9-3	4
	88	28		1-7	60	S43717201	4	10	S50147001	12	4
S25410050	3	34	S38201000	1-23-1-8	46	S43981000	11-1-17	64	S50148001	15	4
S25413101	10	34		1-24-3	47	S44629002	60	2	S50149101	15-2	4
S25417001	11	34	S38349001		78	S46454000	1-4	60	S50150001	17	4
S25418101	12	34	S38350001		78	S46455000	1-5	60	S50152001	20	4
S25420051	15	34	S38352101	6	47	S46703000	1-1-7-1	44	S50153001	22	4
S25456001	22	30			78	S47595000	30-2-2	50	S50154001	1-1	6
S25642001	13/16	75	S38353101	7	47	S47664000	1-2	60	S50155001	4	6
S25789000	5	34			78	S47665000	1-3	60	S50156001	6-1	6
S29023000	1-1-7-3	44	S38735001	5-2	22	S47668000	1-8	60	S50157001	8	6
S30205000	1-16	60	S38736101	24	34	S47669000	1-9	60	S50159001	10	6
S30209000	1-15	60	S38761001	16-5	10	S47670000	1-10	60	S50160001	10-1	6
S30280000	1-1-7-6	44		23-2	10	S47673000	1-13	60	S50161000	11	6
S30564000	31-6	30	S38820000	1-17	46	S47678000	1-14	60	S50162001	12	6
	51-9	32	S39819000	1-23-9	47	S47680000	1-21	60	S50163001	12-1	6
S30565003	31-7	30	S40616001	56-1	56	S47681000	1-22	60	S50164001	12-2	6
S30565005	40-8	30	S40617000	56-1-1	56	S47693000	1-23-5	47	S50165001	12-3	6
S31012001	34	10	S40618000	56-1-2	56	S47694000	1-23-3	47	S50166001	15	6
S31013001	33	10	S40619000	56-1-3	56	S47720000	1-23-1-4	46	S50167001	16	6
S31032001	51-10	32	S40620000	57	56	S47721001	1-23	46	S50168001	17	6
S31808001	18	4	S40621000	1-23-10	47	S47723201	1-6	46	S50169001	1	8
S32263001	40	2		12	64	S47724000	1-23-6	47	S50170001	7	8
S32335100	24-1	58	S40623000	30-1-6	50	S47725000	1-23-1-19	46	S50171001	9	8
S32521001	17	8		30-2-6	50	S47726000	1-23-1-20	46	S50172001	11	8
S35095000	1-2	30		30-3-6	50	S47727000	1-23-1-18	46	S50174001	14	8
S35184001	20-1	14		30-4-6	54	S47728000	1-23-1-17	46	S50176001	18	8
S35598000	56-1-5	56		901	58	S47729000	1-23-1-22	46	S50178001	18-1	8
S35630001	1	75		904	58	S47730000	1-23-1-16	46	S50179001	21	8
S36522001	100-11	74	S40639001	54-6	68	S47733000	1-23-1-10	46	S50180065	14	4
	120-2	74	S40641001	54-12	68	S47734000	1-23-1-14	46	S50180070	14	4
S36924001		78	S41216000	60	58	S47735000	1-23-1-6	46	S50180075	14	4
S37055001	23	58	S41466001	21	20	S47749101	1-6-1	46	S50180080	14	4
S37059001	1-32	47	S41964000	50-1-4	50	S47750000	3	62	S50180085	14	4
		78		50-2-4	50	S48034001	10-2	6	S50180090	14	4
S37060001	1-33	47		51-1-4	52	S48371060	14	4	S50180475	13	70
		78		51-2-4	54	S48371065	14	4	S50180490	13	70
S37100101	46-2	16		51-3-4	54	S48371070	14	4	S50182000	1	8
S37100102		76		51-4-4	56	S48371075	14	4	S50183001	1	10
S37101102		76	S42116000	7	10	S48371080	14	4	S50184001	6	10
S37102101	46-4	16	S42227009	1-19	46	S48371090	14	4	S50185001	8	10
		76	S42653000	900	58	S48579000	1-1-7-4	44	S50186001	10	10
S37103101		76	S42699000	1-17	60	S49492000	1-1-2	44	S50187001	12	10
S37109102		76	S42890001	11-2	64	S49495000	1-1-3	44	S50188001	16-1	10

索引 / INDEX

CODE	REF.NO	Page	CODE	REF.NO	Page	CODE	REF.NO	Page	CODE	REF.NO	Page
S50189001	16-1-1	10	S50247001	10-1	40	S50326001	58	42	S50388001	48	30
S50190001	16-1-2	10	S50248001	10-4	40	S50327001	62	42	S50389001	50	30
S50191001	16-1-3	10	S50249001	17	40	S50328001	63	42	S50390101	51-1	30
S50192001	16-2	10	S50252001	19	40	S50329000	65	42	S50391001	51-2	30
	17	10	S50253001	25	40	S50330101	1	70	S50392001	64	32
S50193001	21	10	S50257001	26	40	S50331000	1-1	70	S50393000	68	32
S50194001	23	10	S50258001	28	40	S50332000	1-2	70	S50394001	1	36
S50195001	23-1	10	S50259101	30	40	S50334000	1-4	70	S50395001	6-1	36
S50196001	24	10	S50260101	30-1	40	S50335000	1-8	70		7-1	36
S50197001	29	10	S50263001	30-2	40	S50336000	1-9	70	S50398001	6-2	36
S50198001	29-1	10	S50264000	30-3	40	S50337000	1-10	70	S50399101	6-3	36
S50199001	29-2	10	S50265001	32	40	S50338000	2	70	S50400001	6-4	36
S50200001	32	10	S50269000	35	40	S50339001	8	70		7-4	36
S50201001	37	10	S50270000	36	40	S50340000	57	2	S50401001	6-6	36
S50202001	38	10	S50271000	5-6	4	S50341001	1-1-3	62		7-6	36
S50203001	42	10	S50272000	5-7	4		1-1-3	62	S50402001	6-7	36
S50204001	43	10	S50273000	1	22		1-1-3	62		7-7	36
S50205001	48	12	S50274001	10	22		1-2-3	62	S50403001	16-1	36
S50206001	50	12	S50275001	12	22		1-2-3	62	S50404201	22	36
S50207001	1	14	S50276001	1	34		1-2-3	62	S50405101	22-1	36
S50208001	5-1	14	S50278001	2	34	S50342000	4	70	S50408001	24-1	36
S50209000	8	14	S50279001	6	34	S50343000	55	72	S50410001	28	36
S50210001	9	14	S50280001	13	34	S50344001	59	72	S50411001	29	36
S50211001	11	14	S50281000	27	34	S50345001	68	72		10-2	40
S50212001	13-1	14	S50282000	29	34	S50346001	80	72	S50412000	30	36
S50213001	14-1	14	S50283001	1	20	S50348001	80-3	72	S50413001	31	36
S50214001	16-1	14	S50284001	3	20	S50349001	80-5	72	S50414001	33-1	38
S50215101	22	14	S50285001	4	20	S50350001	120	74	S50415001	33-2	38
	10-17	64	S50286001	4-1	20	S50351001	120-3	74	S50416001	33-3	38
S50216001	25	14	S50287001	4-2	20	S50354000	4	44	S50417001	35-1	38
S50217001	27-1-1	14	S50288001	5	20	S50356001	8	26	S50418001	35-2	38
S50218001	27-1-2	14	S50289001	10	20	S50359001	13	26	S50419001	33	38
	27-2-2	18	S50290001	10-1	20	S50360001	15	26	S50420001	35-5	38
S50219101	27-1-3	14	S50291001	10-2	20	S50362001	31	20	S50421001	1	46
	27-2-3	18	S50292001	10-3	20	S50363000	34	20	S50422000	1-14	46
S50220001	33-1	14	S50293001	10-4	20	S50364001	35	20	S50423000	1-18	46
S50221001	36	14	S50294001	12	20	S50365101	38	20	S50424000	1-20	46
S50222001	38	14	S50295001	14	20	S50366001	40	20	S50425001	1-24	47
S50223100	39	14	S50296001	16	20	S50368001	1	30	S50431001	1-25	47
S50224001	42	14	S50297001	19	20	S50369001	1-1	30	S50437000	1-27	47
S50225001	33-2	14		1-1-2	62	S50370001	3	30	S50438000	1-28	47
S50226001	1	24		1-1-2	62	S50371101	5	30	S50439000	1-29	47
S50227001	2-1	24		1-1-2	62	S50372001	7-1	30	S50440000	1-30	47
S50228001	2-1-1	24		1-2-2	62	S50373001	7-2	30	S50441000	1-31	47
S50229000	2-1-2	24		1-2-2	62	S50374001	7-5	30	S50442001	30-1	50
S50230001	4	24		1-2-2	62	S50375001	7-6	30	S50443000	30-1-1	50
S50231100	7	24	S50298101	22	20	S50376001	7-7	30	S50444001	30-2	50
S50232000	6	24	S50299101	22-1	20		15	30	S50445000	30-2-1	50
S50233001	10	24	S50300001	23	20		26	30		30-3-1	50
S50234901	20	24	S50303001	42-1	40	S50377001	16	30		30-4-1	54
S50235901	20-1	24	S50304001	1-1-1	62	S50378001	18	30	S50446001	30-3	50
S50236001	20-1-2	24	S50309001	1-1-1	62	S50379001	21	30	S50447001	30-4	54
S50237001	20-2	24	S50311001	1-1-1	62	S50380000	23	30	S50448000	30-5	54
S50239001	20-2-4	24	S50313101	1-2-1	62	S50381000	24	30	S50451201	1-1	44
	21	24	S50317101	1-2-1	62	S50382001	25	30	S50453000	1-1-7	44
S50240001	1	22	S50319101	1-2-1	62	S50383001	29	30	S50455000	1-1-7-2	44
S50241001	2	22	S50321001		77	S50384101	32	30	S50456000	1-1-7-7	44
S50243001	5	22	S50322101		77		56	32	S50457000	1-1-8	44
S50244001	5-1	22	S50323000	50	42	S50385001	39	30	S50458100	1	58
S50245001	6	22	S50324001	52-1	42	S50386001	40-5	30	S50459100	2	58
S50246001	1-1	40	S50325001	57	42	S50387001	40-6	30	S50460000	3	58

CODE	REF.NO	Page	CODE	REF.NO	Page	CODE	REF.NO	Page	CODE	REF.NO	Page
S50461000	4	58	S50525000	41	26	S51020000	87	28	S52761001	4	36
S50462000	5	58	S50527000	43	26	S51117001	1/4	75	S52763000	39	26
S50463000	7	58	S50528000	44	26	S51118001	1-16	46	S52764001	2	26
S50464000	7-1	58	S50529000	45	26	S51162001	28	20	S52770000	42-2	40
	9	58	S50530000	46	26	S51170001	10	40	S52778001	42	40
S50465000	11	58	S50531000	47	26	S51171001	1	40	S52943001	5-3	4
S50466000	16	58	S50532000	48	26	S51172001	52	42	S53181000	3	44
S50467000	16-1	58	S50533000	56	26	S51173001	6	22	S53902301	1	60
S50468000	18	58	S50536001	57	26	S51174001	16	10	S53996101	5	62
S50471000	24	58	S50537000	60	26	S51176001	1	6	S53997000	5-1	62
S50472000	24-2	58		74	28	S51178101	27-1	14	S53998001	5-2	62
S50473000	24-3	58	S50538001	61	26	S51179101	6	36	S54027001	50-1-1	50
S50474000	50-1-3	50	S50539000	62	26	S51180001	16	36		50-2-1	50
	50-2-3	50	S50540001	63	26	S51181001	35	38		51-1-1	52
	51-1-3	52	S50541001	65	28	S51182101	51	30		51-2-1	54
	51-2-3	54	S50542001	67	28	S51183001	40	30		51-3-1	54
	51-3-3	54	S50543001	69-1	28	S51184001	31	30		51-4-1	56
	51-4-3	56	S50544000	69-2	28	S51185001	7	30	S54028001	50-1-2	50
S50476001	120-1	74	S50545000	72	28	S51190001	12	8		50-2-2	50
S50477001	100	74	S50546000	73	28	S51223001	6	6		51-1-2	52
S50483100	52	48	S50547000	75	28	S51225001	6	14		51-2-2	54
S50484000	1-35	47	S50548001	77	28	S51226001	2	24		51-3-2	54
S50485100	50-1-7-2	50	S50549000	79	28	S51248101	66-2	42		51-4-2	56
	50-2-7-2	52	S50550001	80	28			77	S54501101	10	64
	51-1-7-2	52	S50551001	82	28	S51249101		77	S54502101	27-2	18
	51-2-7-2	54	S50552000	84	28	S51250101		77	S54503001	27-2-1	18
	51-3-7-2	54	S50556000	17	26	S51282001	54-5	68		10-1	64
	51-4-7-2	56	S50557000	22	26	S51283001	54-3	68	S54504001	33-3	18
S50486100	50-1-7-3	50	S50558000	23	26	S51290001	34-1	70		10-2	64
	50-2-7-3	52	S50559001	20	26		3/8	75	S54505001	33-3-1	18
	51-1-7-3	52	S50562001	45	14	S51351001	7/16	75		10-2-1	64
	51-2-7-3	54	S50563000	18	26	S51352001	18-1	20	S54506001	33-3-2	18
	51-3-7-3	54	S50564000	19	26		1/2	75		10-2-2	64
	51-4-7-3	56	S50565001	50	58	S51353001	9/16	75	S54507001	52	18
S50488100	3	47	S50566001	1-1	46	S51354001	34-2	70		10-3	64
S50498001	56	56	S50567001	1-2	46		5/8	75	S54508001	13-2	18
S50499000	56-2	56	S50568001	1-3	46	S51355001	11/16	75		10-5	64
S50500000	30-6	54	S50632101	50-1	50	S51356001	3/4	75	S54509000	56	18
S50501201	H-1	48	S50633100	50-1-7	50	S51357001	7/8	75		10-6	64
S50502201	H-2	48	S50634101	50-2	50	S51358001	18-2	20	S54510001	57	18
S50503201	H-3	48	S50635100	50-2-7	50		34-3	70		10-7	64
S50504301	H-4	48	S50636101	51-1	52		1	75	S54511001	16-2	18
S50505301	H-5	48	S50637100	51-1-7	52	S51359001	34-5	70		10-9	64
S50506301	H-6	48	S50638101	51-2	54		29	75	S54512001	14-2	18
S50507301	H-7	48	S50639100	51-2-7	54	S51360001	34-4	70		10-10	64
S50508301	H-8	48	S50640101	51-3	54		32	75	S54513001	20-2	18
S50509301	H-9	48	S50641100	51-3-7	54	S51361001	1-1	62		10-11	64
S50510201	H-10	48	S50642101	51-4	56	S51362001	1-1	62	S54514101	46-5	18
S50511001	35-9	38	S50643100	51-4-7	56	S51363001	1-1	62		10-12	64
S50512001	35-10	38	S50644000	61	58	S51364001	1-2	62	S54515001	46-5-2	18
S50513000	24	26	S50644001	1-38	47	S51365001	1-2	62		10-12-1	64
S50514000	25	26	S50645000	1-25-2	47	S51366001	1-2	62			76
S50515000	26	26	S50649000	50-1-7-1	50	S51418001	5	14	S54516101	46-5-1	18
S50516001	27	26		50-2-7-1	50	S51514101		76		10-12-6	64
S50517001	30	26	S50656201	1	44	S51896001	80-1	72	S54517000	47-2	18
S50518000	32	26	S50657001	1	44	S51901201	1-1-1	44		10-13	64
S50519000	33	26	S50660000	1-4	46	S52248001	6	4			76
S50520000	35	26	S50663001		77	S52431000	22-5	36	S54518101	46-6	18
S50521000	36	26	S50664001	66-1	42	S52432001	39	40			76
S50522000	38	26			77	S52433001	39-1	40	S54519001	7	36
S50524000	40	26	S50665001		77	S52434001	39-4	40	S54520001	7-2	36

索引 / INDEX

CODE	REF.NO	Page	CODE	REF.NO	Page	CODE	REF.NO	Page	CODE	REF.NO	Page
S54520001	10-14	64									
S54521001	7-3	36									
	10-15	64									
S54522001	66-3	42									
	10-16	64									
		77									
S54741001	9	24									
S54763001	69	28									
S54767000	150	74									
S54768001	1-3	70									
S54987001	46-5-6	18									
	10-12-5	64									
S55344001		77									
S55345002		76									
S55346002		76									
S55347002		76									
S55348001		76									
S55349001		76									
S55350001		76									
S55361100	151	74									
S55663001	35	70									
S55975001	62	32									
S56251001	24-4	36									
S58097001	24	36									
S58098001	24-2	36									
S58731000	1-23	60									
S58971001	11-1	64									
S58972000	11-1-5	64									
S58973000	11-1-19	64									
S58974000	1-1-11	44									
S58978001	11-1-18	64									
S58984000	4	44									
S58987001	1-1-12	44									
S58988001	11	64									
S58989001	11	64									
S59987001	17-1	40									
SA0287000	63	58									
U32744000	1-20	60									
U34870001	1-1-7-5	44									
XA2220050	1-1-9	44									
Y42215591	1-11	60									
Y44715591	1-25-3	47									
Y44715591	1-12	60									

brother®



パーツブック
PARTS BOOK

ブラザー工業株式会社

〒467-8561 名古屋市瑞穂区苗代町 15 番 1 号 TEL (052) 824-2392

BROTHER INDUSTRIES, LTD

15-1, Naeshiro-cho, Mizuho-ku, Nagoya 467-8561, Japan. Phone : 81-52-824-2177

Printed in Japan

118-H80
S96H80-101
2002.05.F (1)

From the library of: Superior Sewing Machine & Supply LLC